

## NEMA 34 I-Grade Motor/Encoder Hybrid Servo Motor



QCI-A34HC-1



IP65 (-6T Option)

Note: Motor specifications (including torque curves) measured using QCI-N3-IX controllers with 2 foot motor cables.

## General Motor Specifications

\*Maximum current (amps) drawn from power supply for the “48V Max” and “48V” torque curves respectively (see below for details).

<i>Specifications</i>	<b>A34HC-1</b>	<b>A34HC-2</b>	<b>A34HC-3</b>	<b>A34HC-4</b>	<b>A34C-1</b>	<b>A34C-2</b>
<b>Maximum Speed (RPM)</b>	3000	2500	2000	1500	2500	2500
Optimal Speed (RPM) (best power and efficiency)	1600	1600	1000	800	1200	700
Torque at Optimal Speed oz-in / Nm	350 2.5	390 2.7	770 5.4	990 6.7	320 2.3	651 4.6
Continuous Stall Torque oz-in / Nm	675 4.8	1300 9.2	1950 13.8	2550 18.0	540 3.7	1048 7.4
Peak Power (Mech. Watts)	440	565	580	515	285	340
Rotor Inertia oz-in <sup>2</sup> / Kg-m <sup>2</sup>	7.8 1.4E-4	14.7 2.7E-4	21.9 4.0E-4	29.0 5.3E-4	7.65 1.4e-4	14.8 2.7e-4
Weight pounds / Kg	5.7 2.6	9.1 4.1	12.6 5.7	15.8 7.2	5.3 2.4	8.5 3.9
Power Supply Amps* 48V Max/48V	13.7 13.2	16.5 15.5	16.0 16.0	14.5 14.5	10	10.5
Shaft Diameter in/ mm	0.500 12.70	0.500 12.70	0.625 15.88	0.625 15.88	.500 12.7	.500 12.7
Maximum Radial Force lbs/Newton 0.79"/ 20mm from mounting face	65 290	65 290	65 290	65 290	49 220	49 220
Maximum Axial Force lbs Newtons	305 1300	305 1300	305 1300	305 1300	13.5 60	13.5 60
Notes: Maximum power shown using 48V power supply. Maximum power is approximately 1.5x larger when using a 72v power supply. Current Draw is approximately the same.						

## Torque Curves

48V Max is the torque of the motor when the Torque Limits (TQL) command is set to “Max” (see SilverLode Command Reference for details on the TQL command). Operating the motor in this mode requires proper heat sinking on the Controller/Driver and motor to prevent overheating. Torques, power, and efficiencies measured using N3-IX controllers with 2’ cables

All other torque curves represent motor torque at the specified voltage when the TQL command is set to “100%”. These curves represent torque up to 100% duty cycle depending on ambient temperature, heat sinking and air flow.

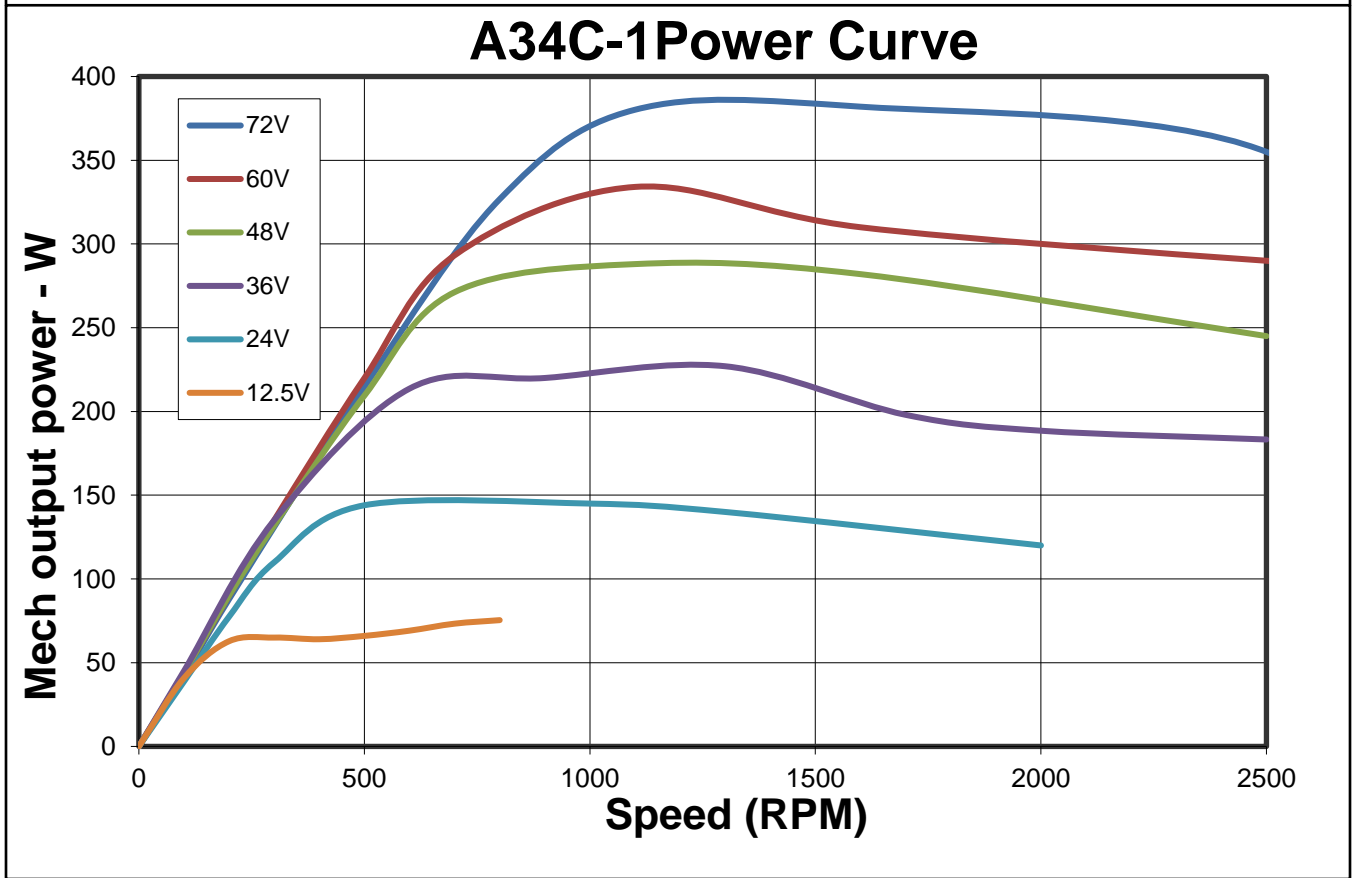
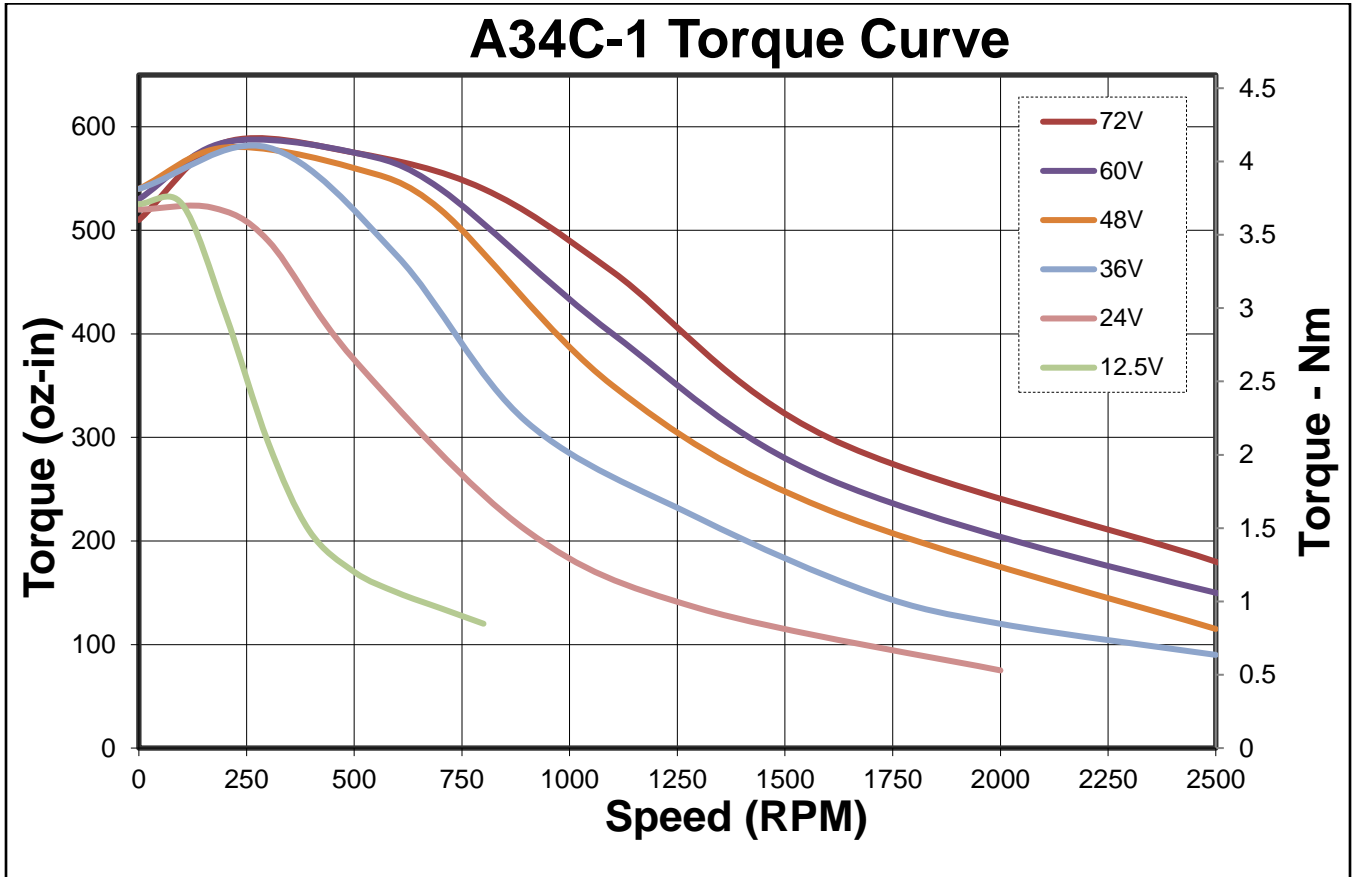

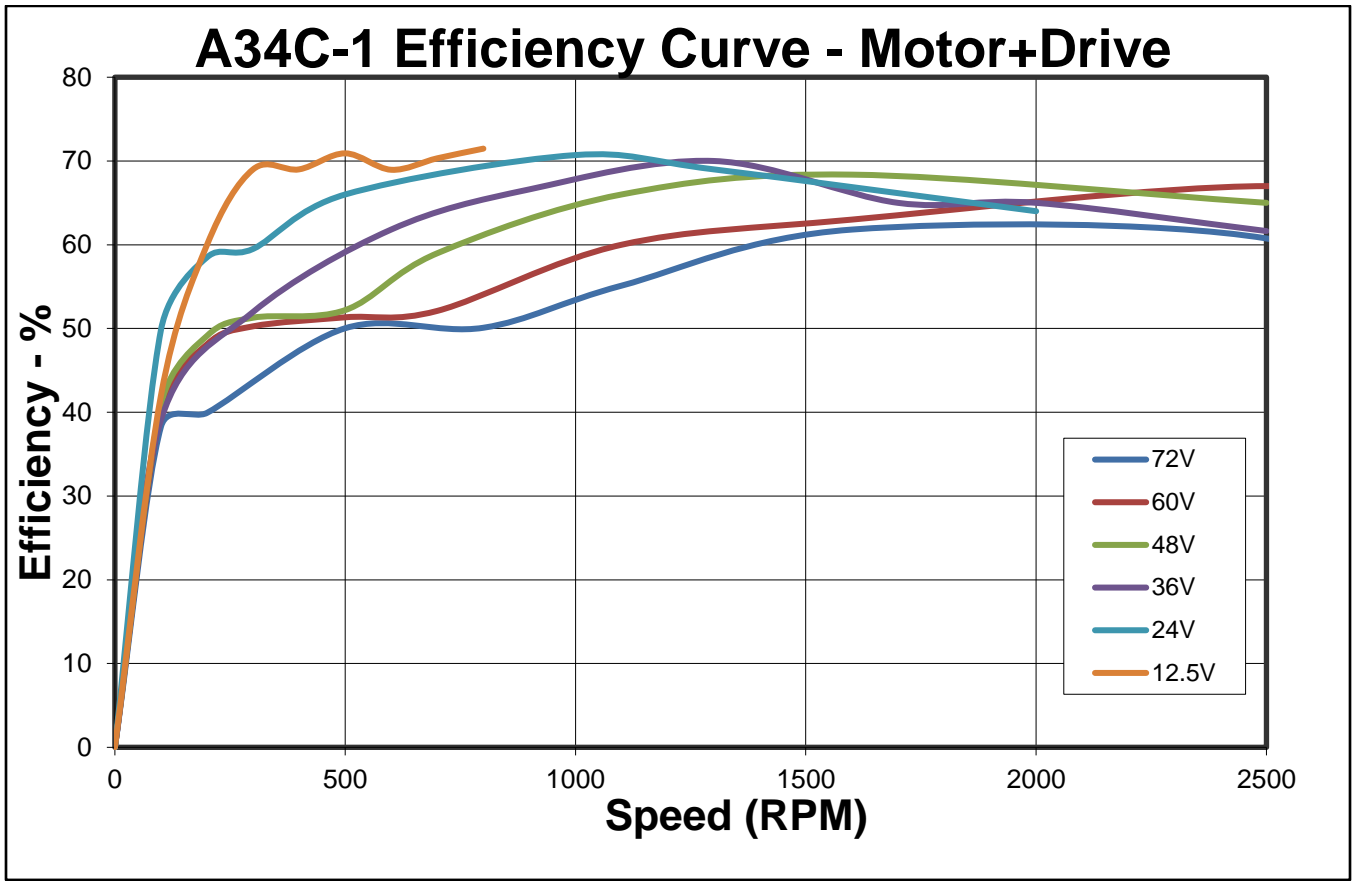

Note: All torque curves taken N3-IX with 2' cable; voltage measured at controller input.

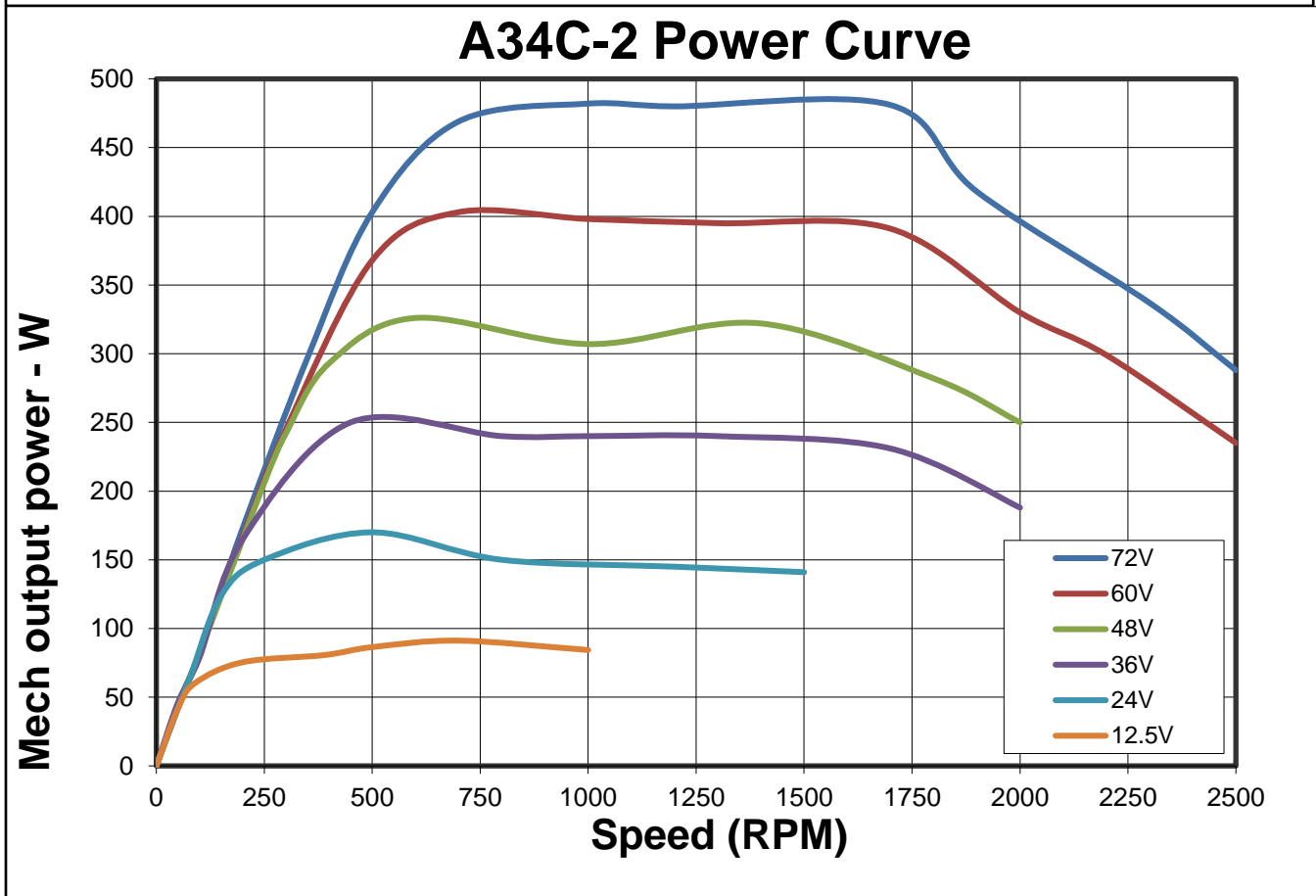
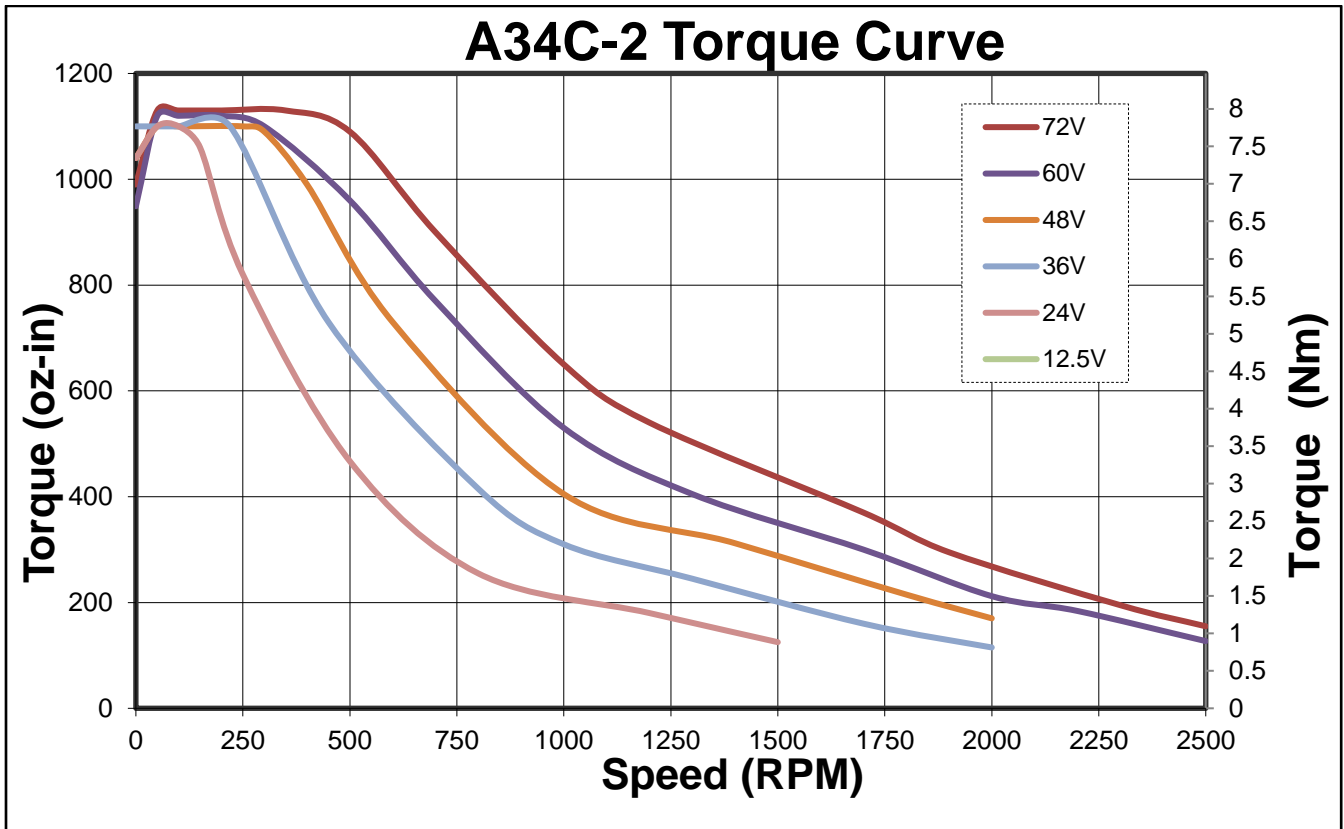

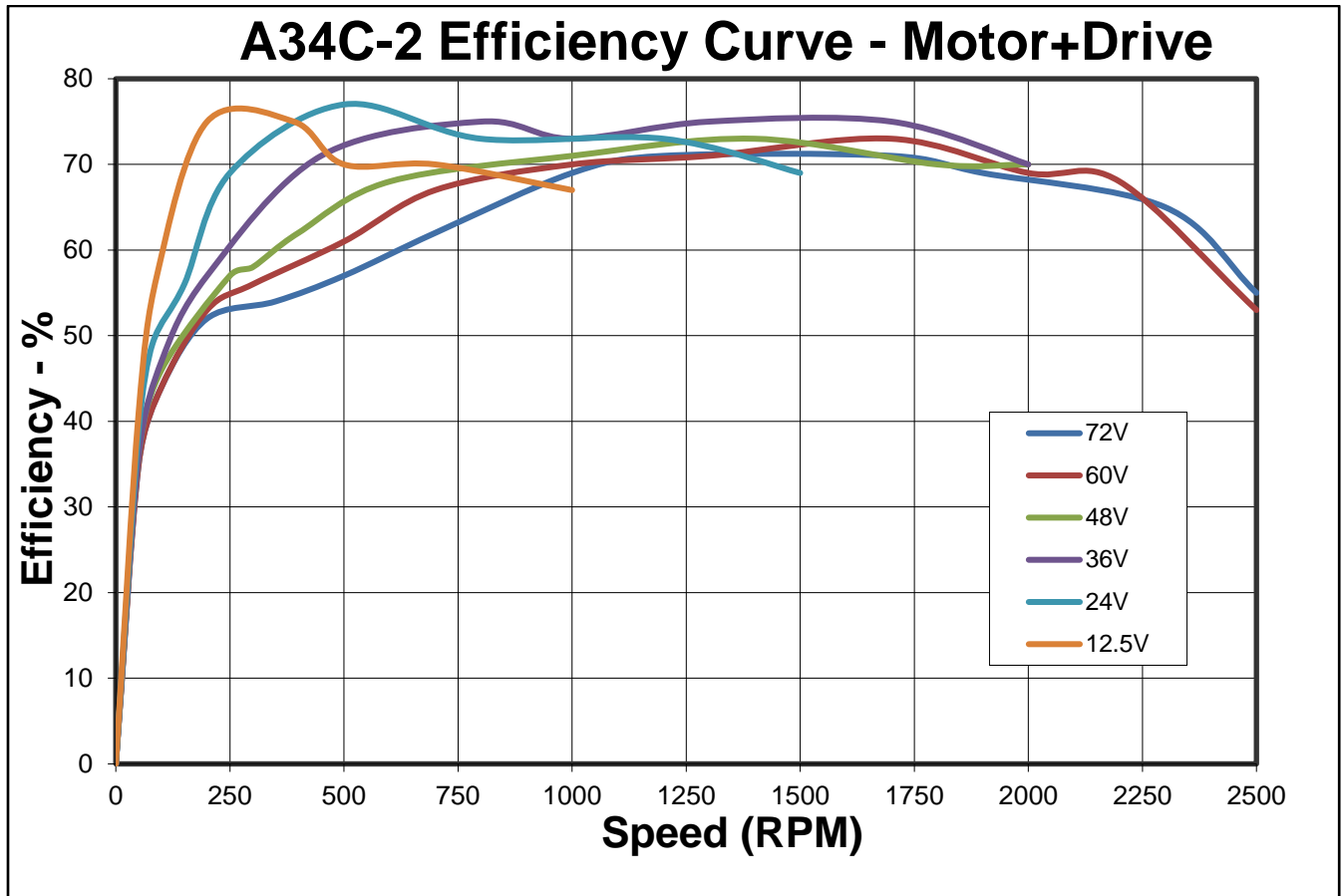

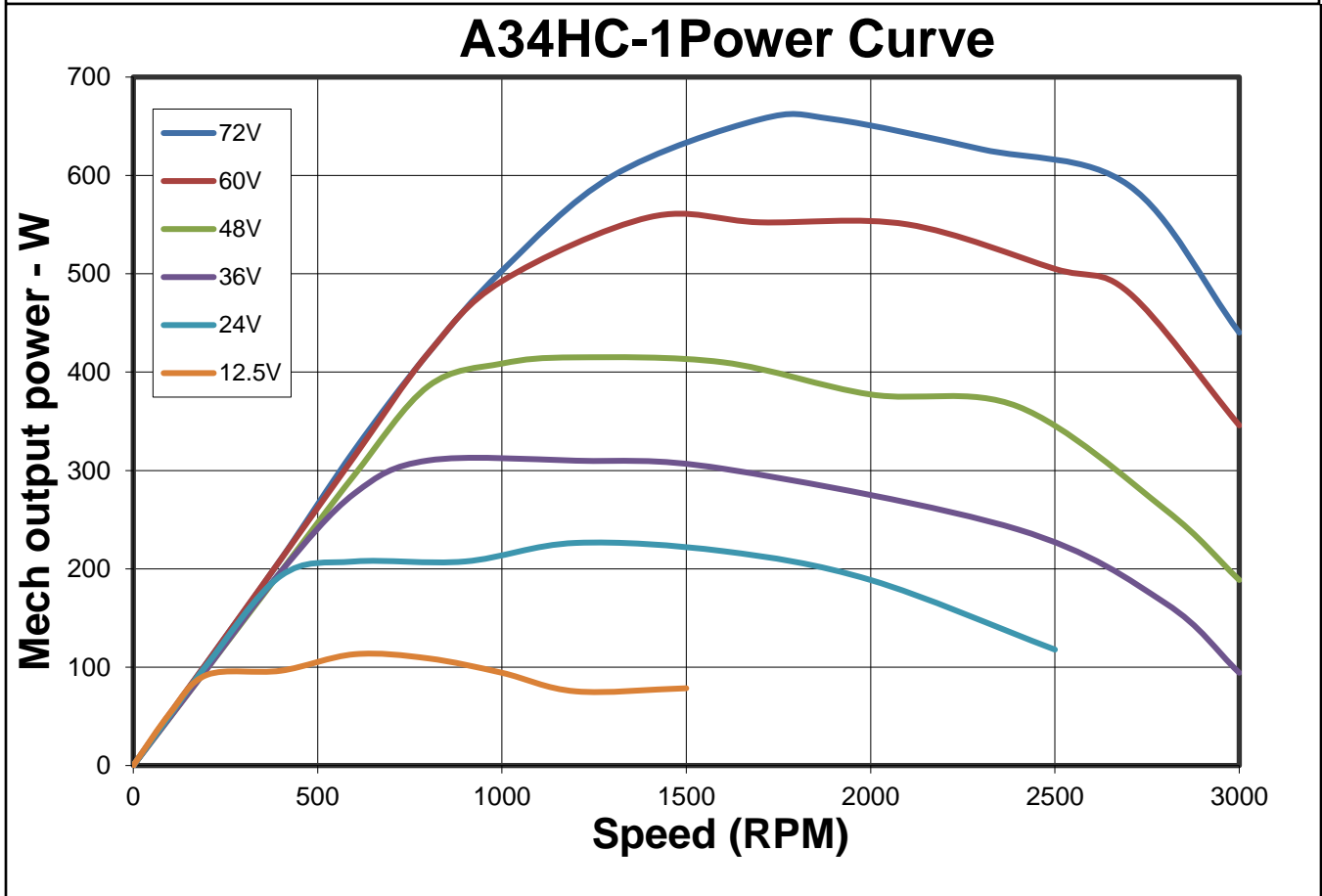
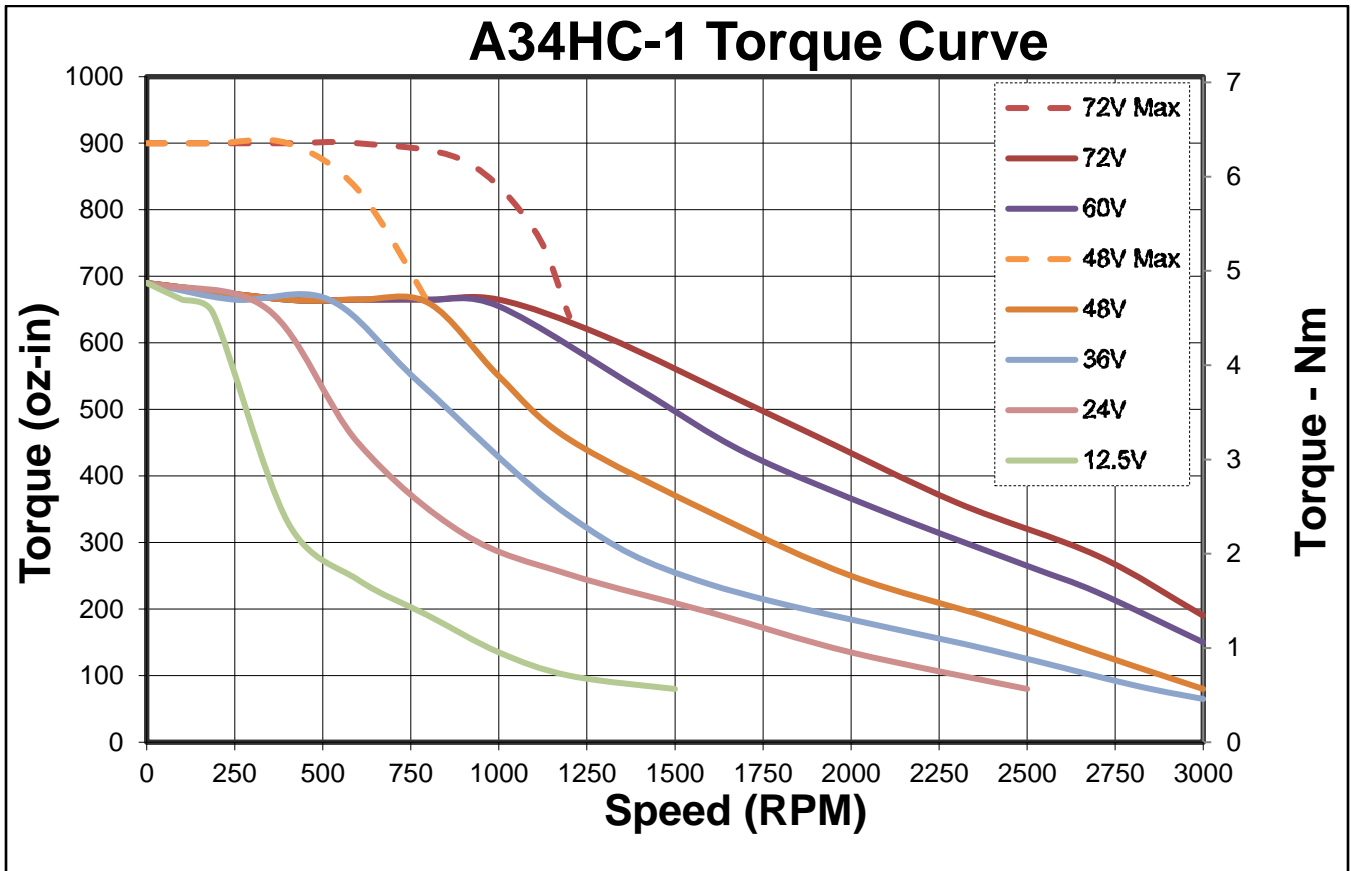

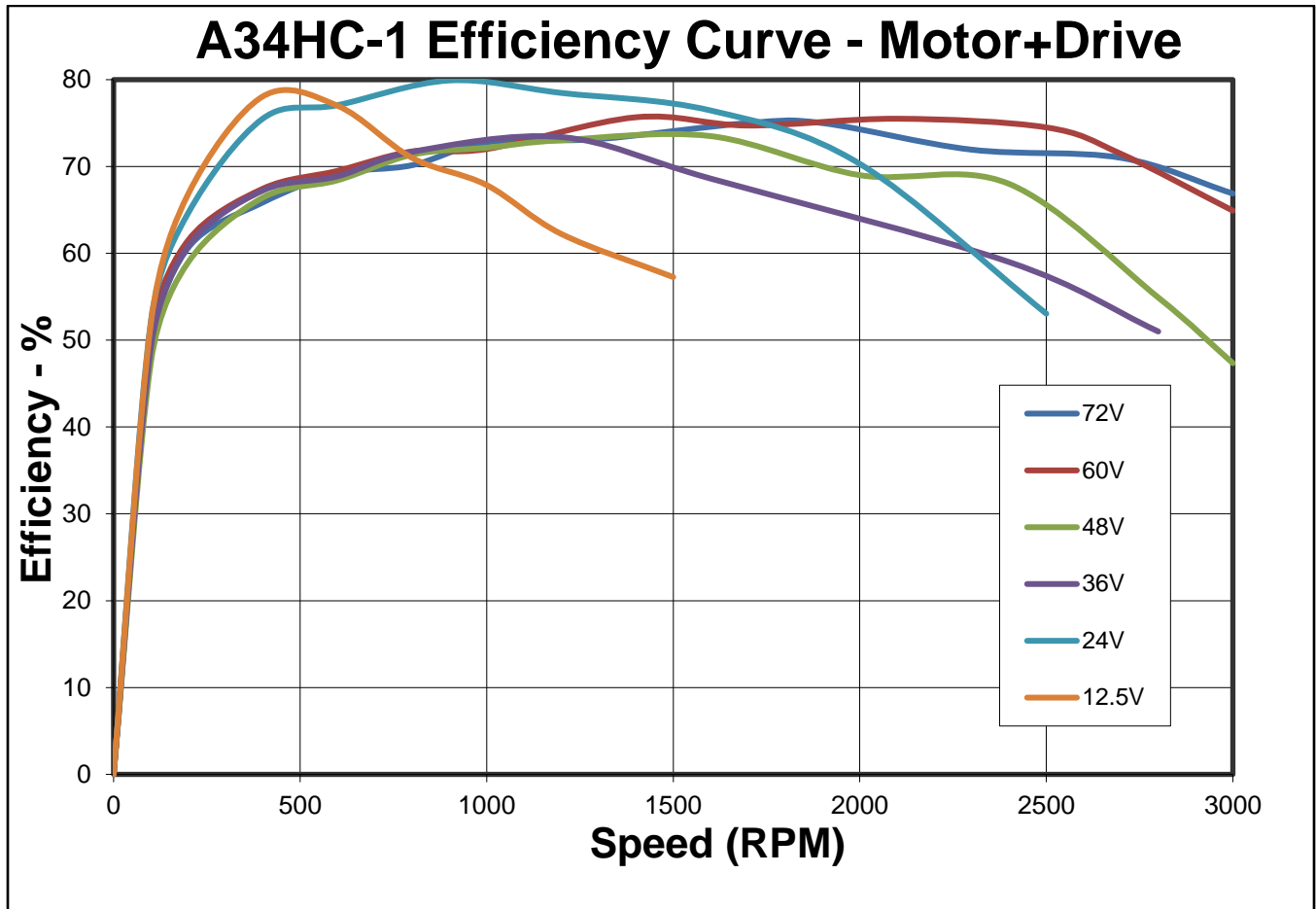



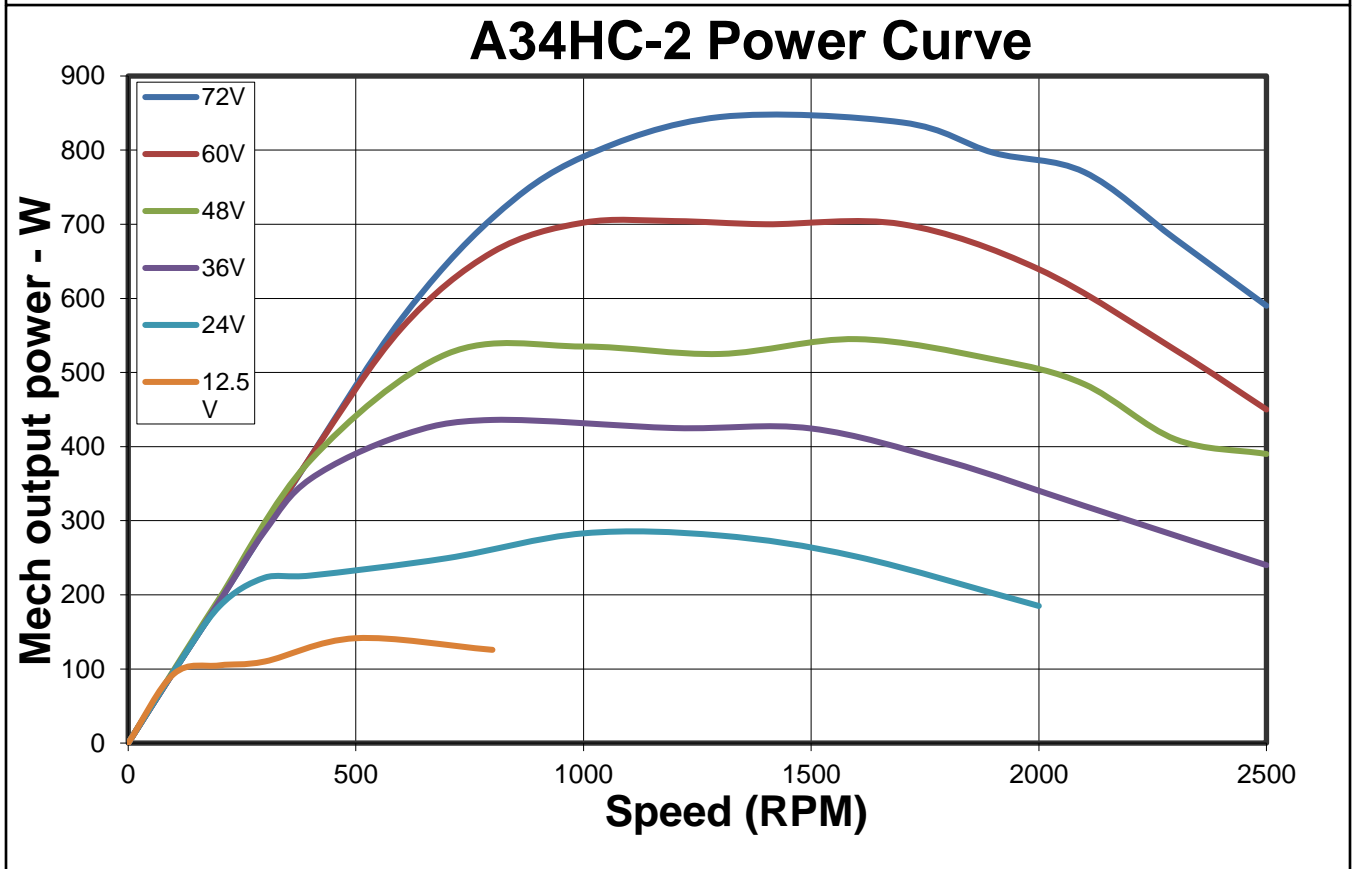
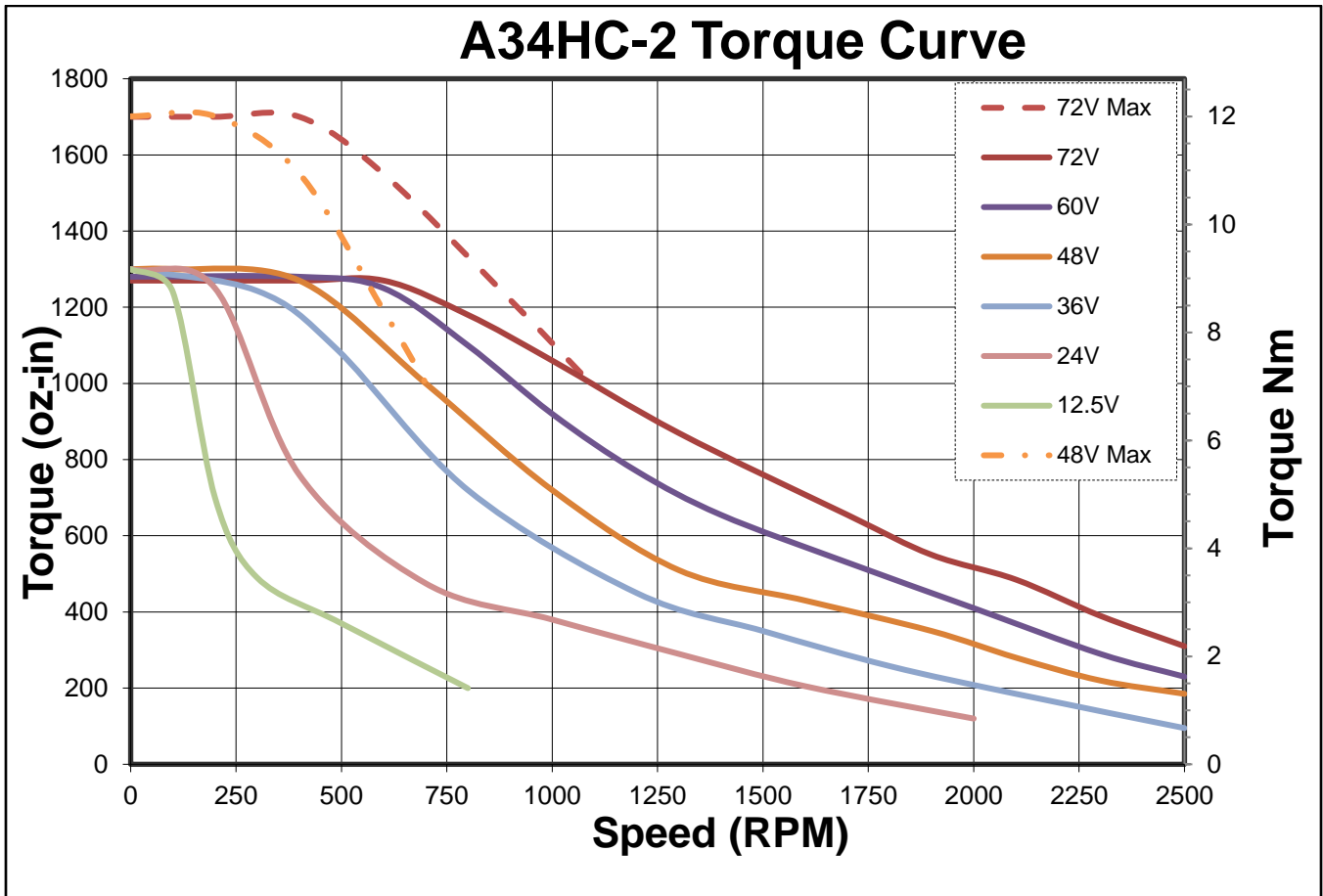

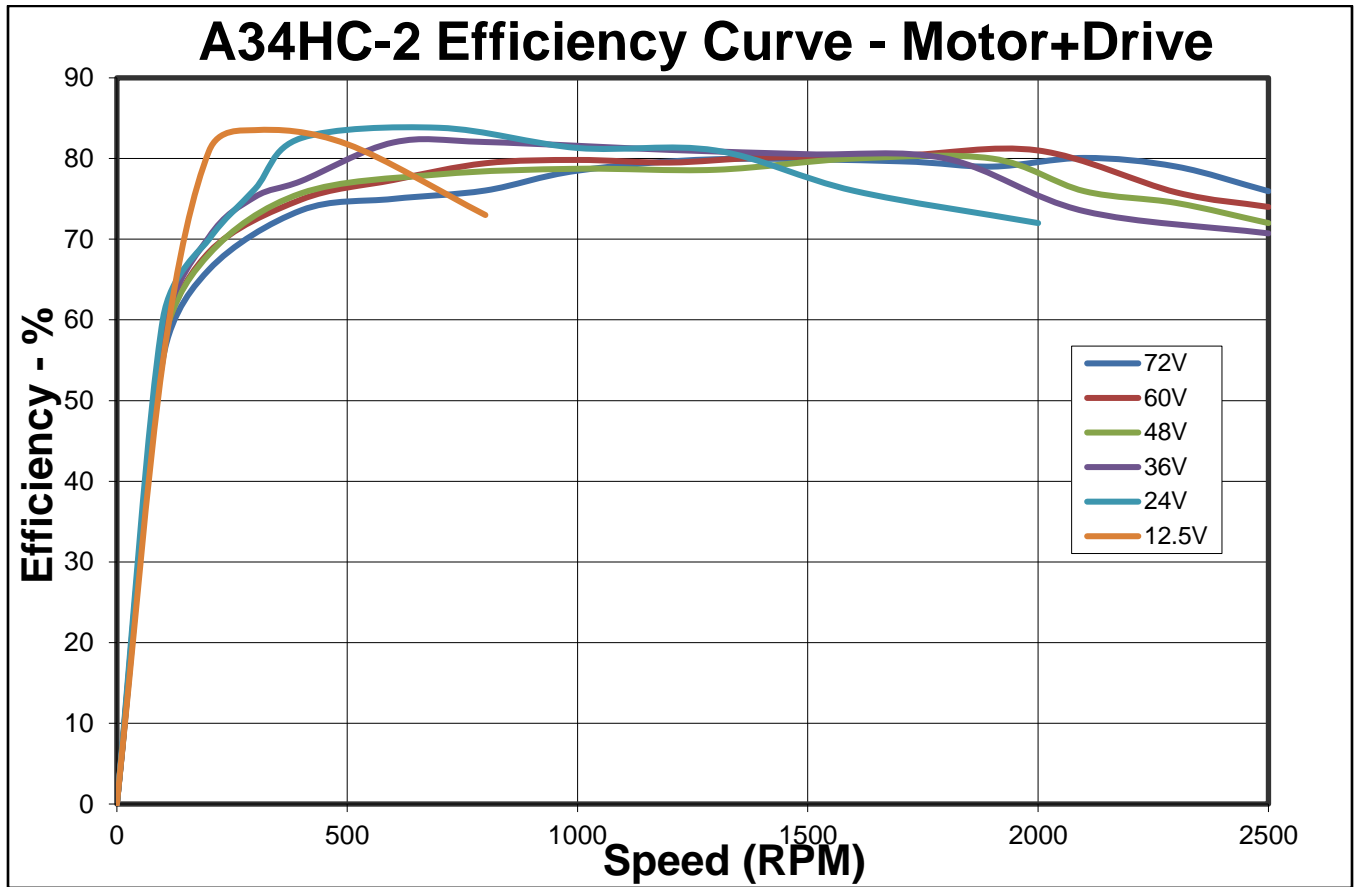

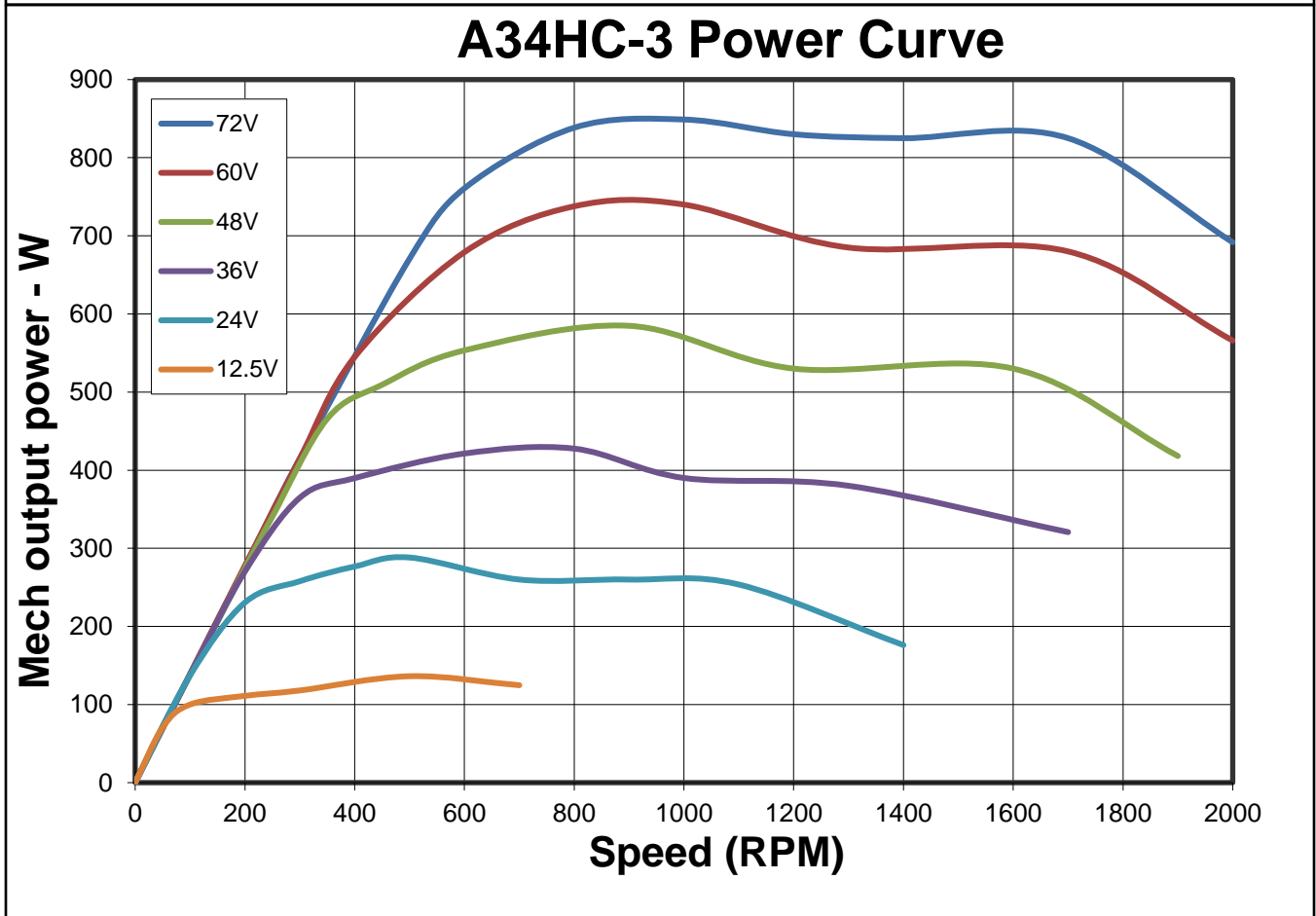
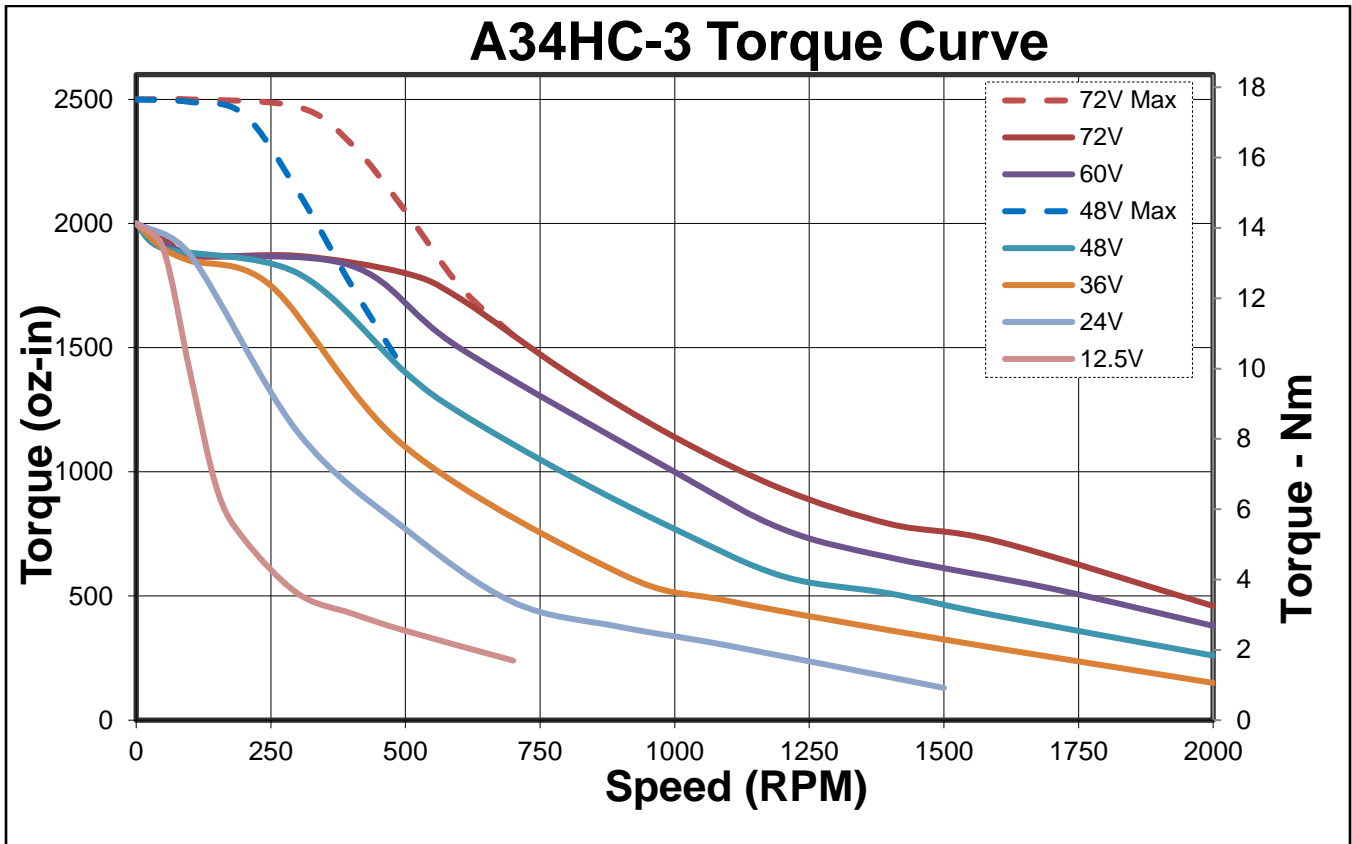

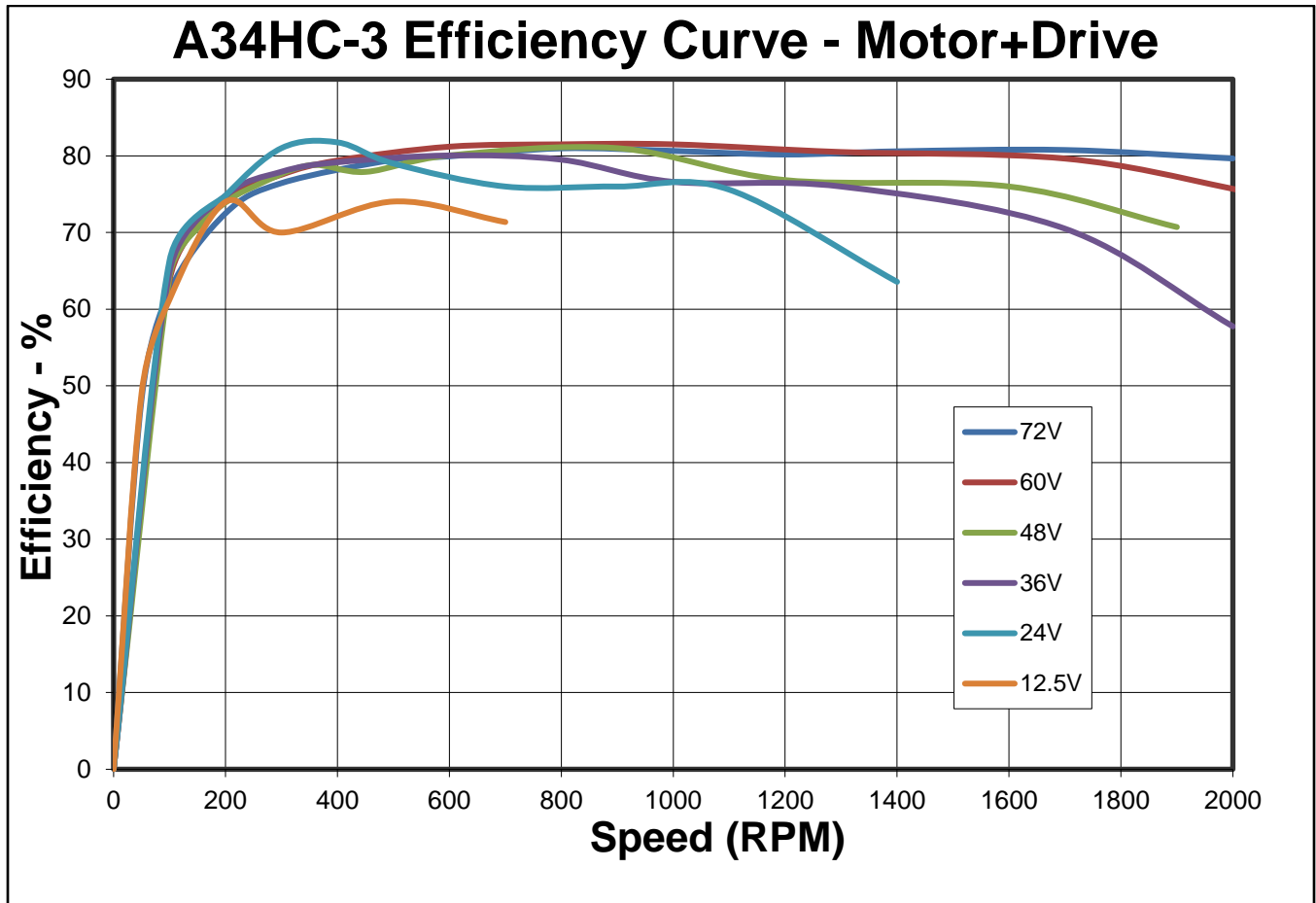

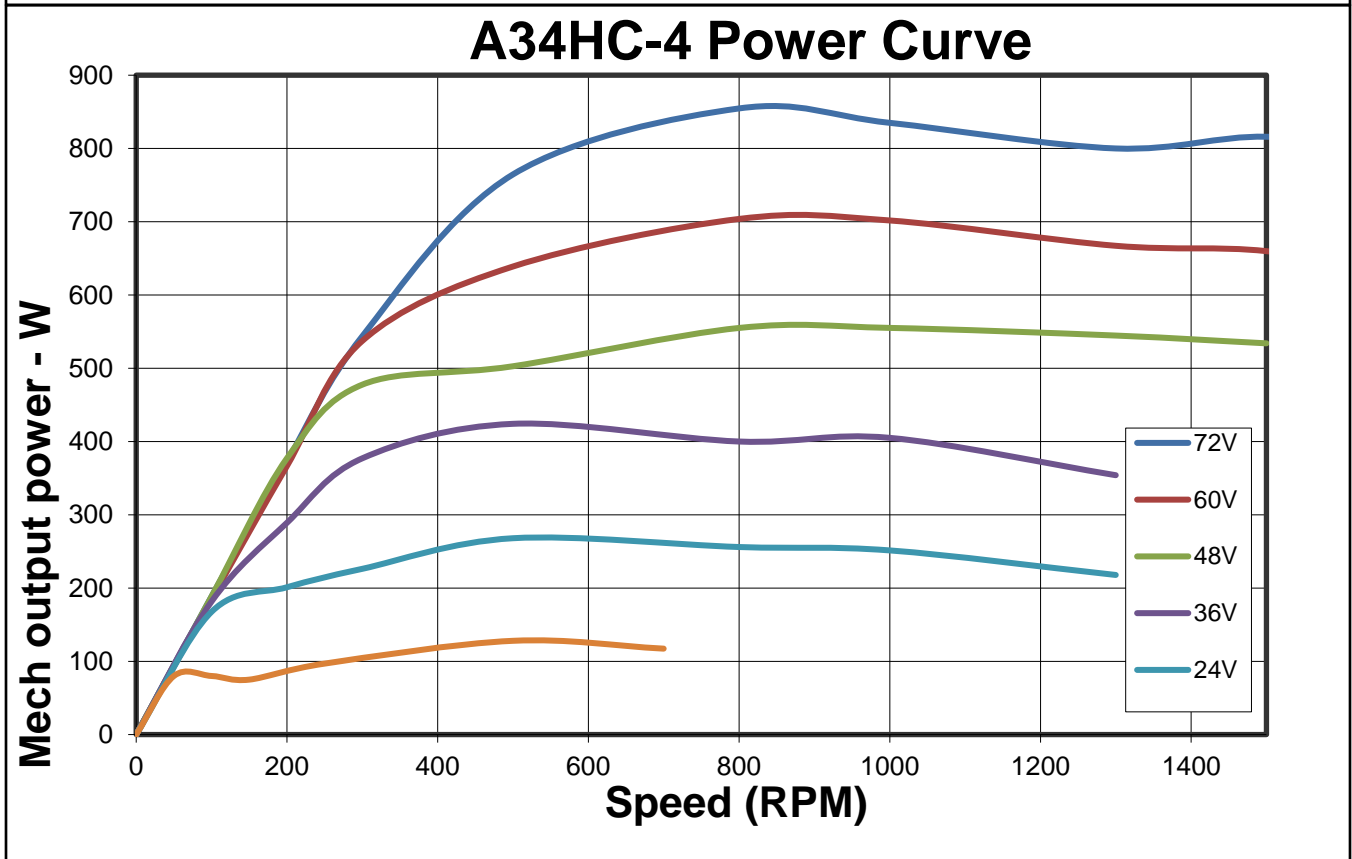
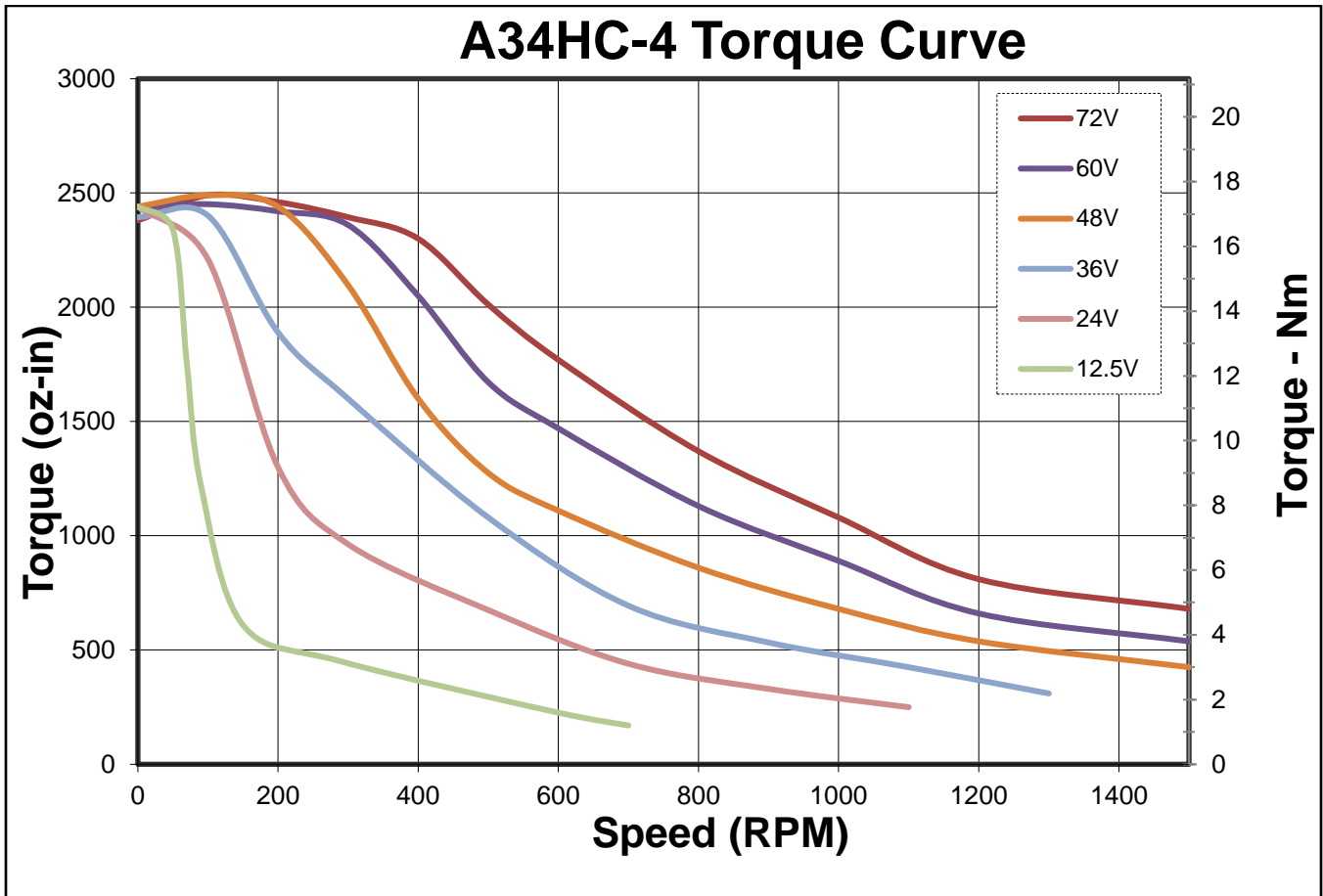

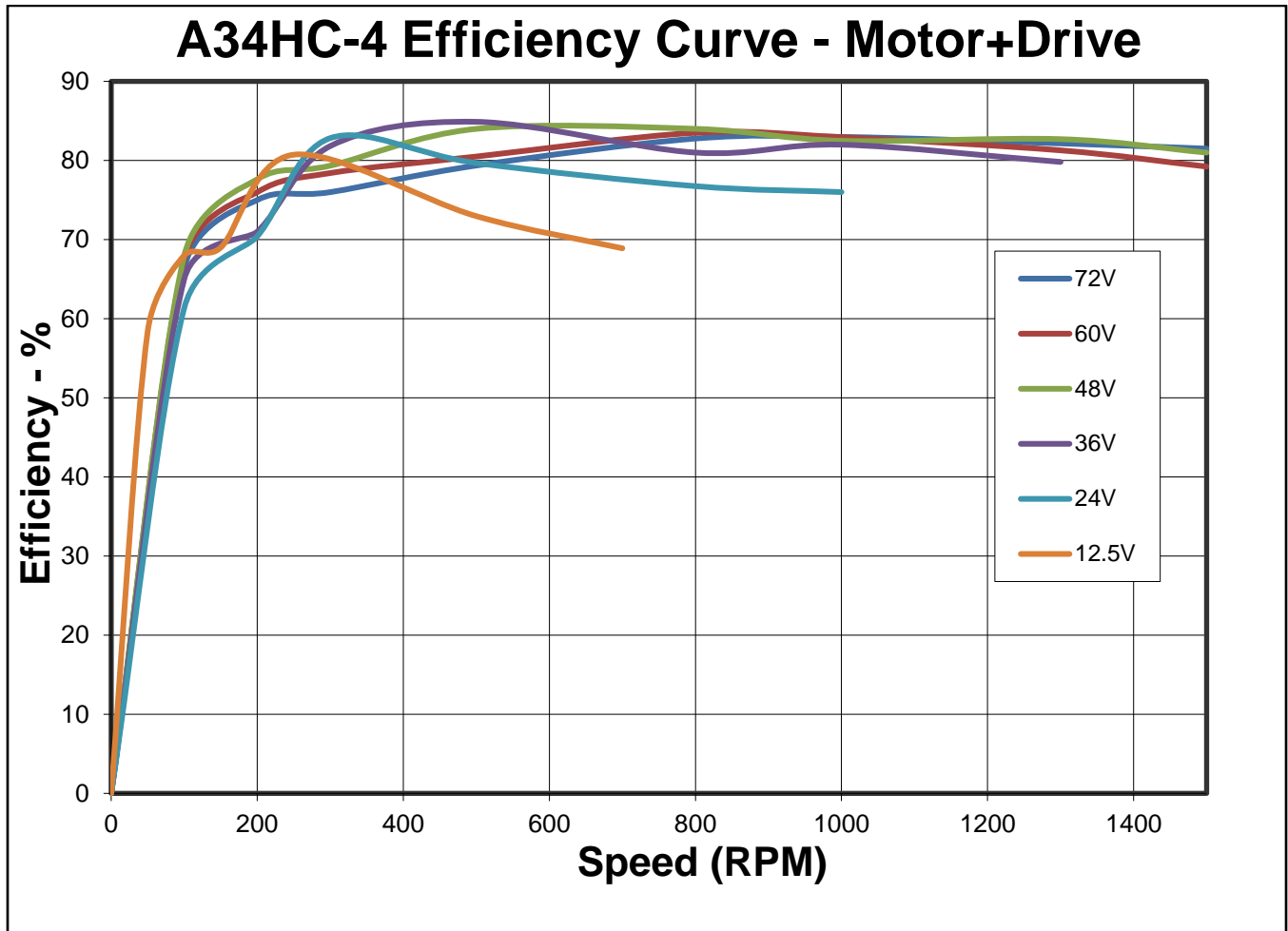

## Electrical Specifications

### Encoder Interface

Encoder Count Per Revolution: 16000

Index Pulse: 49 - SilverLode Controller/Drivers internally translate to a single index pulse.

### Motor Memory

I-Grade motors come from the factory with a memory chip containing encoder and motor information. This information is automatically uploaded by the SilverNugget IG and SilverSterling controller/driver to simplify the initialization process.

## Connector Data

### Standard – 34C, 34HC

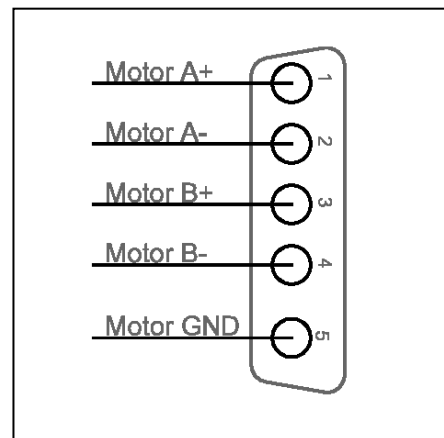
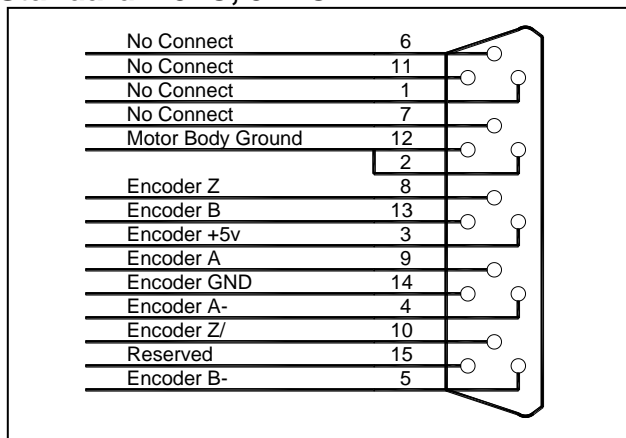

**-6T Option**

IP65 Encoder Connector

Pin	Signals
A	NC
C	+5V
E	Memory
G	NC
J	NC
L	NC
M	Z+
N	Z -
O	A+
P	B -
R	B+
S	GND
T	A-
U	GND

EXPOSED FRONT VIEW OF MOTOR CONNECTOR

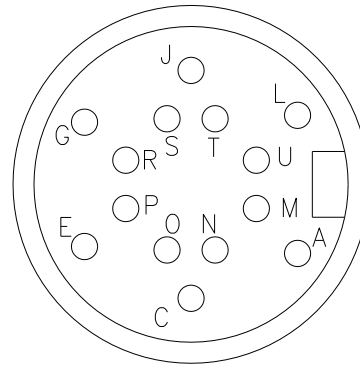

IP65 Motor Power Connector

Pin	Signals
1	Motor A-
2	Motor A+
3	Chassis GND
4	Motor B-
5	Motor B+
6	Chassis GND

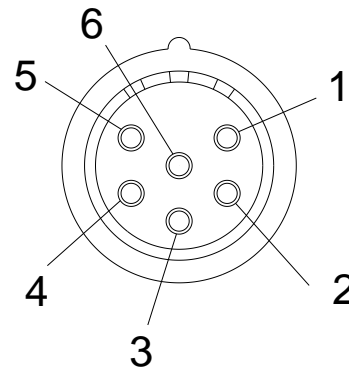



# Mechanical Specifications

## Standard

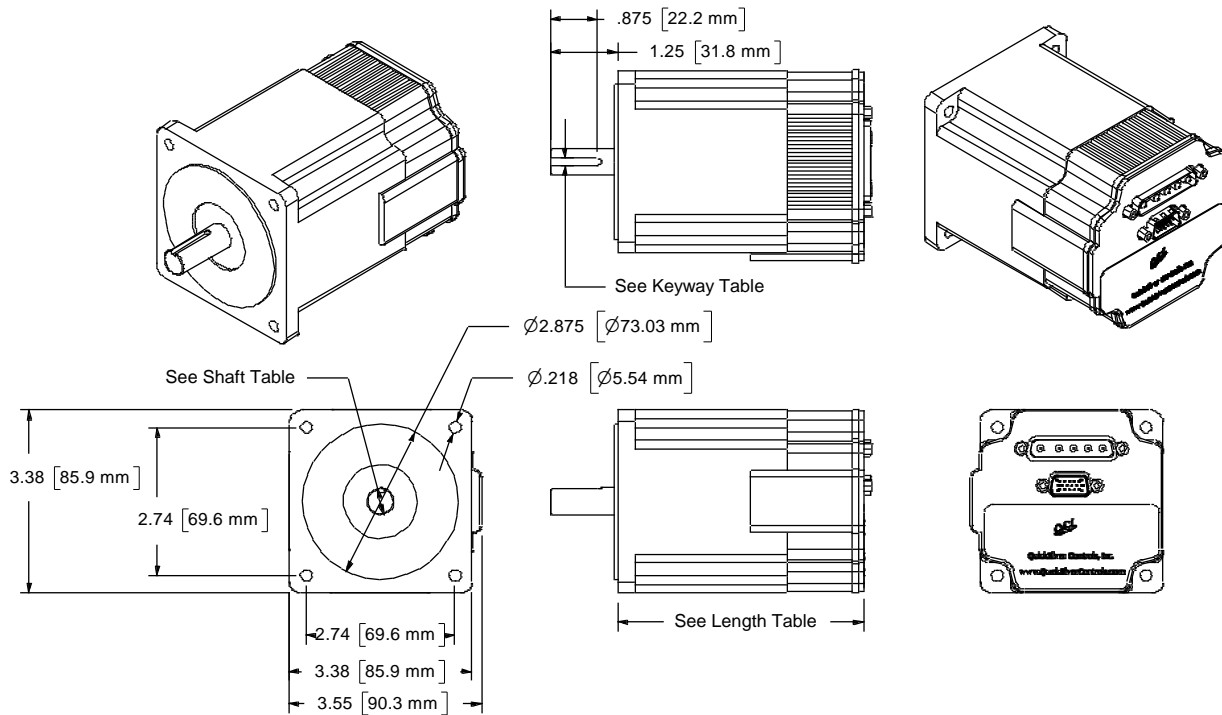

Model	Length	Shaft Diameter	Keyway Width	Notes
34C-1	4.5 [115 mm]	.500 [12.70 mm]	None	
34C-2	6.0 [147 mm]	.500 [12.70 mm]	None	
34HC-1	4.5 [115 mm]	.500 [12.70 mm]	0.125 [3.175 mm]	
34HC-2	6.1 [155 mm]	.500 [12.70 mm]	0.125 [3.175 mm]	
34HC-3	7.6 [193 mm]	.625 [15.875 mm]	0.1875 [4.7625 mm]	
34HC-4	9.2 [232 mm]	.625 [15.875 mm]	0.1875 [4.7625 mm]	

Note: See our website for 2D drawings and 3D models.

**⚠️ Note: The motor construction uses a wave spring to compensate for mechanical tolerances and thermal expansion in the axial shaft direction. It is important to not push the shaft into the motor in operation or when mounting gears or pulleys as this may damage the encoder disk.**

6T Option

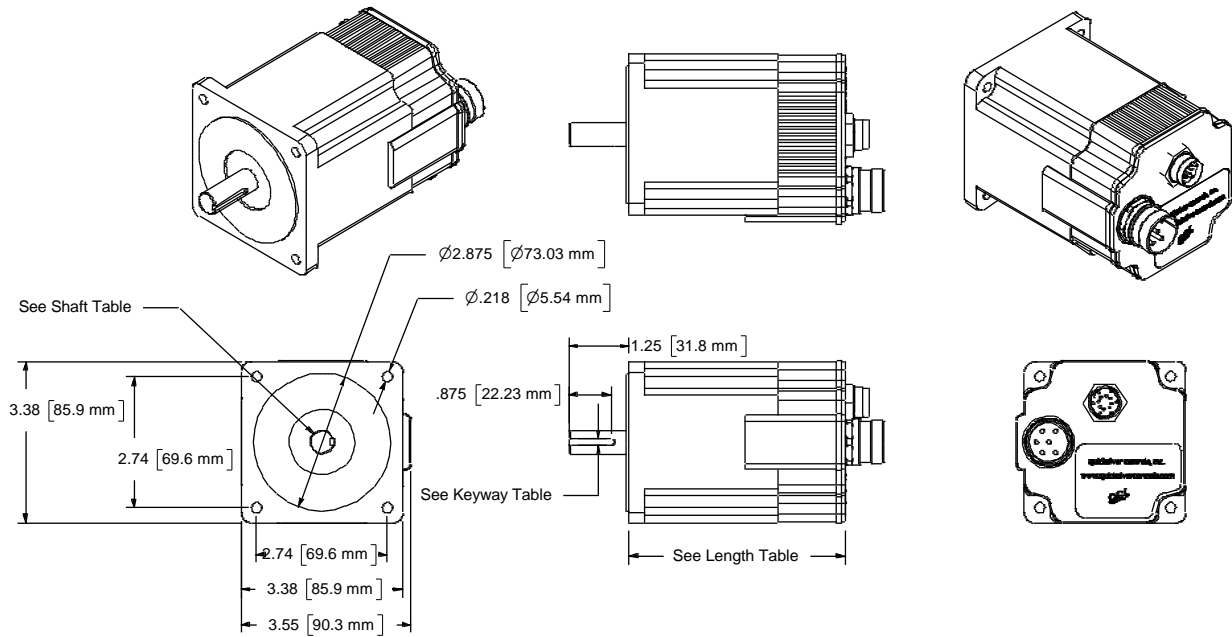

Model	Length	Shaft Diameter	Keyway Width	Notes – IP65 on shaft:
34C-1-6T	4.5 [115 mm]	.500 [12.70 mm]	None	Requires external shaft seal
34C-2-6T	6.0 [147 mm]	.500 [12.70 mm]	None	Requires external shaft seal
34HC-1-6T	4.5 [115 mm]	.500 [12.70 mm]	0.125 [3.175 mm]	May order with Seal
34HC-2-6T	6.1 [155 mm]	.500 [12.70 mm]	0.125 [3.175 mm]	May order with Seal
34HC-3-6T	7.6 [193 mm]	.625 [15.875 mm]	0.1875 [4.7625 mm]	May order with Seal
34HC-4-6T	9.2 [232 mm]	.625 [15.875 mm]	0.1875 [4.7625 mm]	May order with Seal

Note: See our website for 2D drawings and 3D models.

## Environmental Specifications

### Operational Temperature

-10 C to +80 C

### Storage Temperature

- 40 C to +85 C

### Humidity

Continuous specification is 95% RH non-condensing.

### Shock

Limitation is approximately 50g/11ms.

### IP Rating - Standard

IP50

### IP Rating – 6T Option

IP65 is achieved if both a shaft seal and IP65 Motor Interface Cables (QCI-C-D15P-T14S-nn and QCI-C-D15P-T6S) are used. The A34C-x-6T require a separate shaft seal plate for IP65. The A34HC-x-6T may be ordered with optional seal insert.

NOTE: The IP65 rating is for applications with occasional wash downs. It is not meant for continuous wet applications or high-pressure wash downs. See IP65 spec for more details (CEI IEC 529).

## Recommended Components

### Standard Configuration

#### **SilverNugget N3 X-series Controller/Driver (QCI-N3-IX)**

See the SilverNugget I-Grade N3 datasheet (QCI-DS034) for details on designing with these controller/driver.

#### **Encoder Interface Cable (QCI-C-D15P-D15S-nn)**

This cable goes between the motor and the QuickSilver Controller/Driver (SilverNugget). Replace the last two digits “nn” with length of cable in feet (i.e – 10 for 10 feet).

#### **Motor Power Interface Cable (QCI-C-D5P-D5S-nn)**

This cable goes between the motor and the SilverNugget N3. Replace the last two digits “nn” with length of cable in feet (i.e. –10 for 10 feet).

#### **Power Supply (i.e. SE-1000-48 or RSP-1000-48)**

A 12-48V power supply producing the amps specified above (see General Motor Specifications) is required. QuickSilver recommends:

- SE-1000-48 (48V, 20.8A)
- RSP-1000-48 (48V, 20.8A) with power factor correction.

#### **Power Supply Cord w/ Flying Leads (QCI-C-ACP-FLY-6)**

#### **2' SMI Interface Cable (QCI-EC-SMI-02)**

The QCI-EC-SMI-nn is used to connect the SilverNugget N3 X-series controller to the QCI-BOB4 breakout board. Replace the last two digits “nn” with length of cable in feet (i.e. –10 for 10 feet). Standard lengths are 2 and 10 feet

#### **Basic Breakout Board (QCI-BO-B4)**

QCI recommends purchasing a breakout to simplify wiring processor power, RS-485 communication, and 7 LVTTTL I/O. The breakouts connect to the SilverNugget SMI connector through an SMI cable

#### **USB to RS485 converter (QCI-USB-RS485)**

USB-RS-485 converter provides a USB powered serial port with RS-485 signaling. See QCITD073 USB-RS485 Converter Setup Guide for information on network termination and shielding recommendations.

#### **10' Power cable (QCI-EC-P10)**

This cable provides 4 power conductors for V+, V-, and clamp resistor, in addition to a chassis ground connection

#### **50W Clamp Resistors (QCI-R4-50)**

Rapid deceleration of larger loads may require the use of the Primary Clamp circuit, requiring adding external power resistors between Clamp+ and Clamp. The N3-IX has an internal clamp and an external clamp. Additional clamp resistors may be added to the external clamp.

NEMA 34 I-Grade Motors/Encoders	
MOTOR TYPE/SIZE	MOTOR INTERFACE
<ul style="list-style-type: none"> <li>• <b>A34C-1</b></li> <li>• <b>A34C-2</b></li> <li>• <b>A34HC-1</b></li> <li>• <b>A34HC-2</b></li> <li>• <b>A34HC-3</b></li> <li>• <b>A34HC-4</b></li> </ul>	<p><b>Blank</b> – Standard</p> <ul style="list-style-type: none"> <li>• DB15HD Encoder Connector</li> <li>• DB5 Power Connector</li> </ul> <p><b>6T</b> – IP65 (special order)</p> <ul style="list-style-type: none"> <li>• Round Encoder Connector (14-Pin)</li> <li>• Round Power Connector (6-Pin)</li> </ul>
<p>To create a part number, choose one from each column above.</p> <ul style="list-style-type: none"> <li>• For example: IP65 34HC-1 Motor</li> </ul>	
<ul style="list-style-type: none"> <li>• <b>QCI-A34HC-1</b></li> </ul>	<ul style="list-style-type: none"> <li>• <b>6T</b></li> </ul>
<p>This selection creates the part number: <b>QCI-A34HC-1-6T</b></p>	
<p><b>Note: A34C-x-6T require external front shaft seals for IP65</b></p>	

**Standard Items**

- QCI-A34HC-1
- QCI-A34HC-2
- QCI-A34HC-3
- QCI-A34HC-4
- QCI-A34C-1
- QCI-A34C-2

**Contact Information**

QuickSilver Controls, Inc.  
 990 N Amelia Ave  
 San Dimas, CA 91773  
 909-599-6291 or (888) 660-3801  
 909-599-6289 FAX  
[www.QuickSilverControls.com](http://www.QuickSilverControls.com)