

## NEMA 17 I-Grade Motor/Encoder

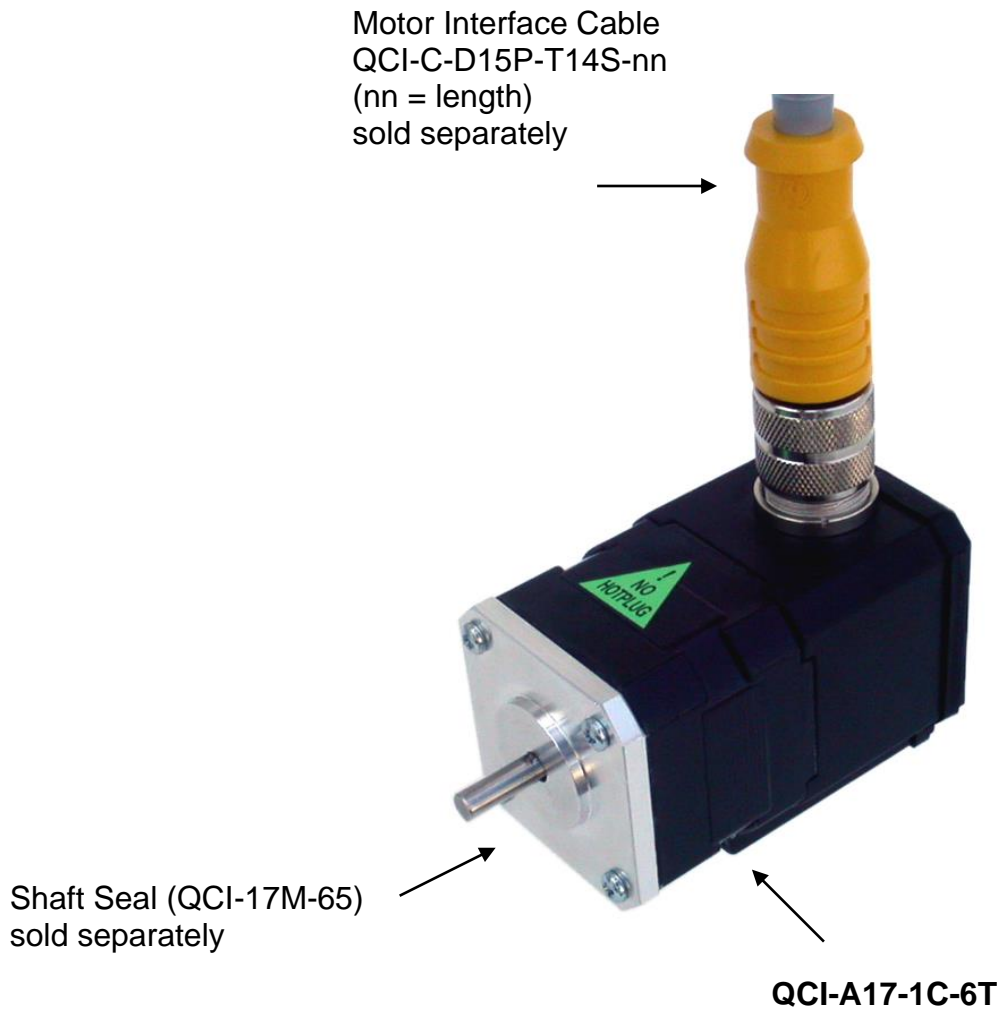

Note: Motor specifications (including torque curves) are only true when the motors are used in conjunction with QuickSilver's SilverLode™ Controller/Drivers (i.e. SilverStering™, SilverNugget™ and SilverDust™). See controller datasheets for more information.

## General Motor Specifications

Specifications	17-1C	17H-3C	17-1	17H-3	17K-1	17-3	17H-1
Maximum Speed (RPM)	2500	4000	2500	4000	2500	2500	4000
Optimal Speed (RPM) (best power and efficiency)	1800	2700	1600	2700	900	1600	2700
Torque at Optimal Speed oz-in / Nm	22 0.16	38 0.27	12 0.08	30 0.21	35 0.25	19 0.13	16 0.11
Continuous Stall Torque oz-in / Nm	32 0.23	47 0.33	21 0.15	43 0.30	42 0.30	36 0.25	23 0.16
Peak Power (Mech. Watts)	32	78	16	69	25	24	34
Rotor Inertia oz-in <sup>2</sup> / Kg-m <sup>2</sup>	0.19 3.4E-6	0.37 6.8E-6	0.19 3.5E-6	0.37 6.8E-6	0.17 3.3E-6	0.37 6.8E-6	0.19 3.5E-6
Weight pounds / Kg	0.63 0.29	0.90 0.40	0.60 0.27	0.90 0.40	0.60 0.27	0.90 0.40	0.60 0.27
Maximum Current (amps) (drawn from power supply)	1.4	4.0	1.3	4.0	2.3	1.5	3.0
Maximum Radial Force (lbs) (20mm from flange) (N)	6.3 28	6.3 28	5 22	5 22	5	5	5
Maximum Axial Force (lbs) (N)	2.2 10	3 10	3 13	3 13	3	3	3
Mounting Screws	M3x0.5	M3x0.5	4-40	4-40	4-40	4-40	4-40

Note: 17-1C is replacement 17-1 (which has gone EOL). The 17-1C has approximately 50% more torque from a higher efficiency design (~58% vs ~36%) and is lower cost. The mounting screws are metric rather than 4-40. The 17-1C will report as a 17-1 in the window and can be swapped with 17-1 motors without re-initializing for back compatibility reasons.

17H-3C is replacement 17H-3 (which has gone EOL). The 17H-3C has approximately 25% more torque from a higher efficiency design (~60% vs ~40%) and is lower cost. The mounting screws are metric rather than 4-40. The 17H-3C will report as a 17H-3 in the window and can be swapped with 17H-3 motors without re-initializing for back compatibility reasons.

Note: The grayed items are EOL; their information is provided for existing installations and for comparison with the replacement motors..

## Torque Curves

48V Max is the torque of the motor when the Torque Limits (TQL) command is set to "Max" (see SilverLode Command Reference for details on the TQL command). Operating the motor

in this mode requires proper heat sinking on the Controller/Driver and motor to prevent overheating.

All other torque curves represent motor torque at the specified voltage when the TQL command is set to "100%". These curves represent torque up to 100% duty cycle depending on ambient temperature, heat sinking and air flow.

Important: There is a slight reduction in torque if the shaft seal (sold separately) is used due to the resistance of the quad seal around the shaft.

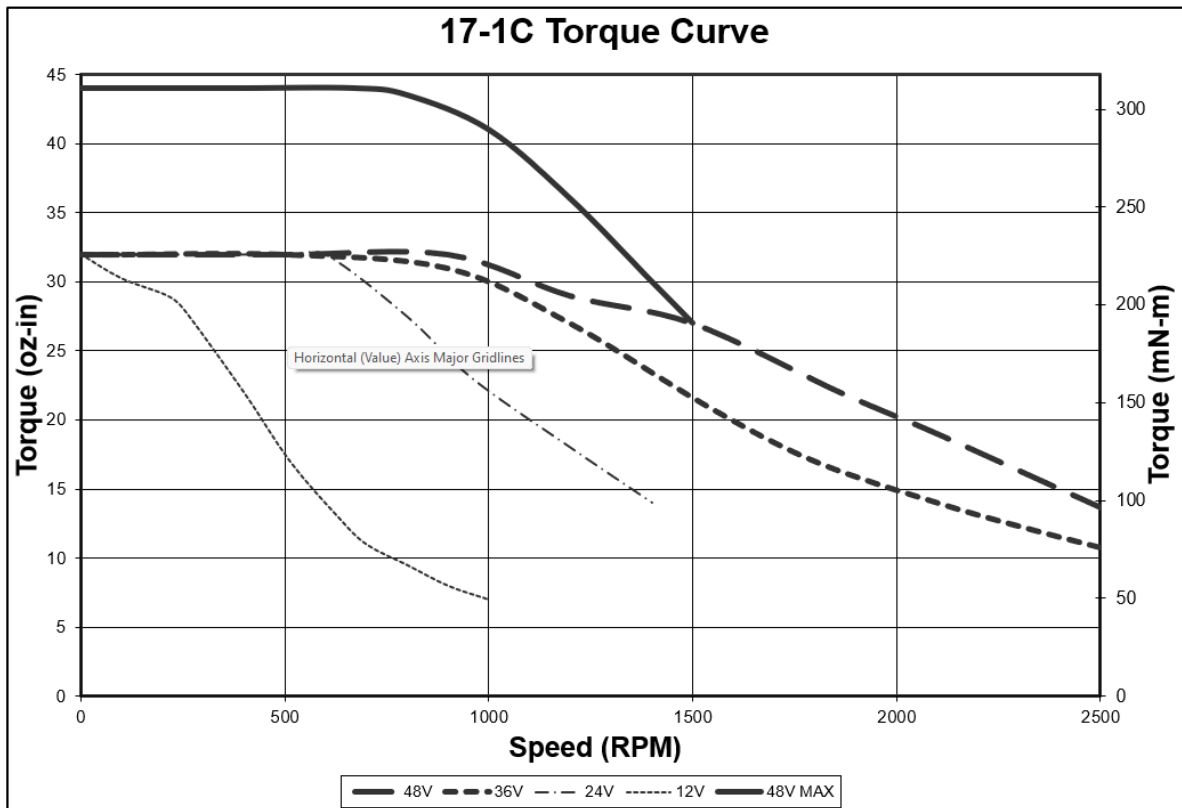

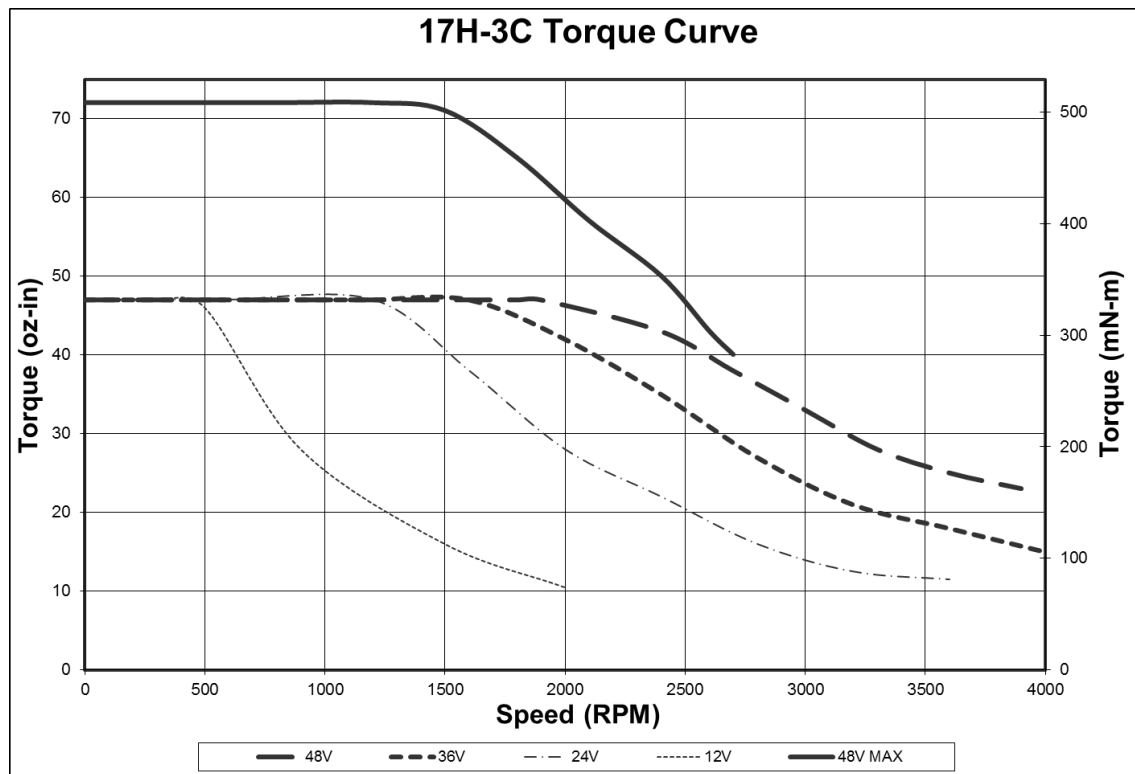
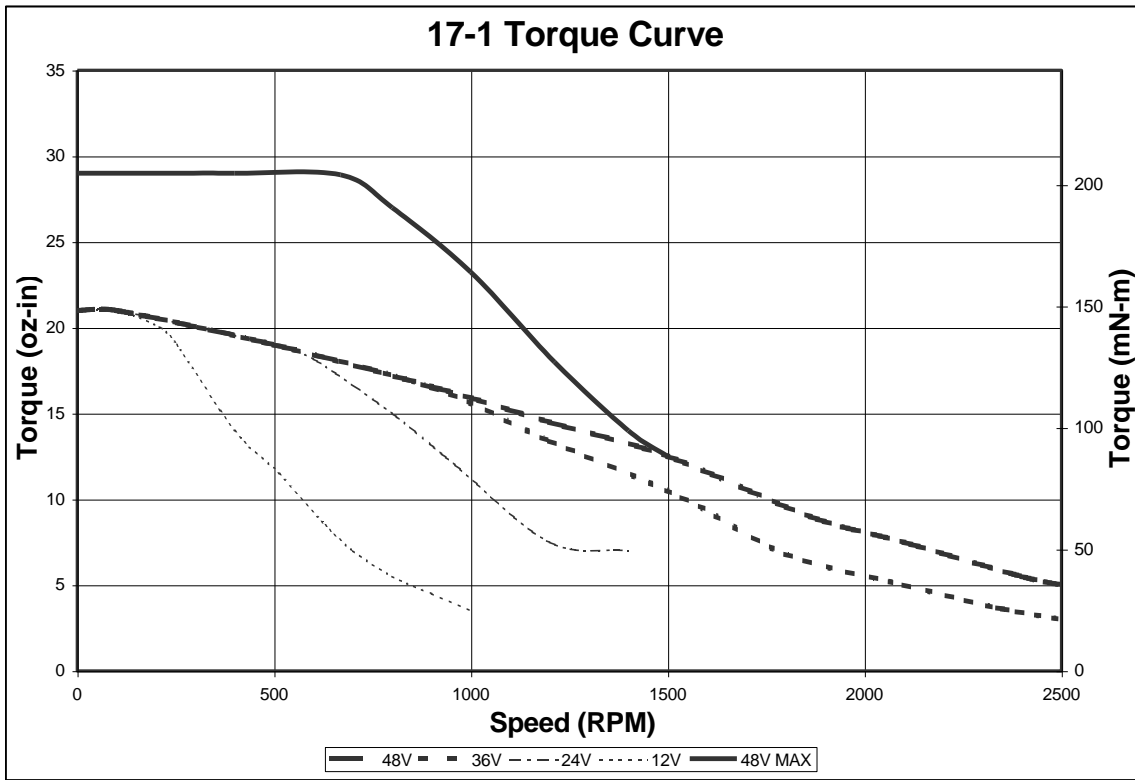

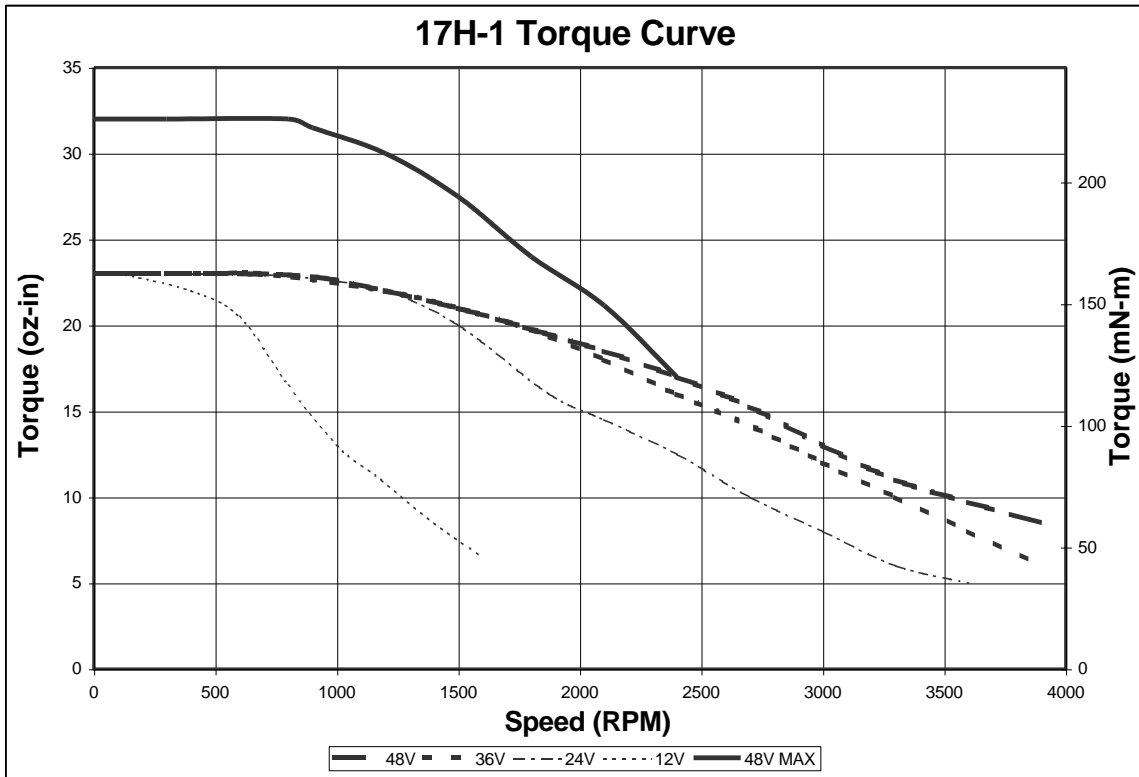
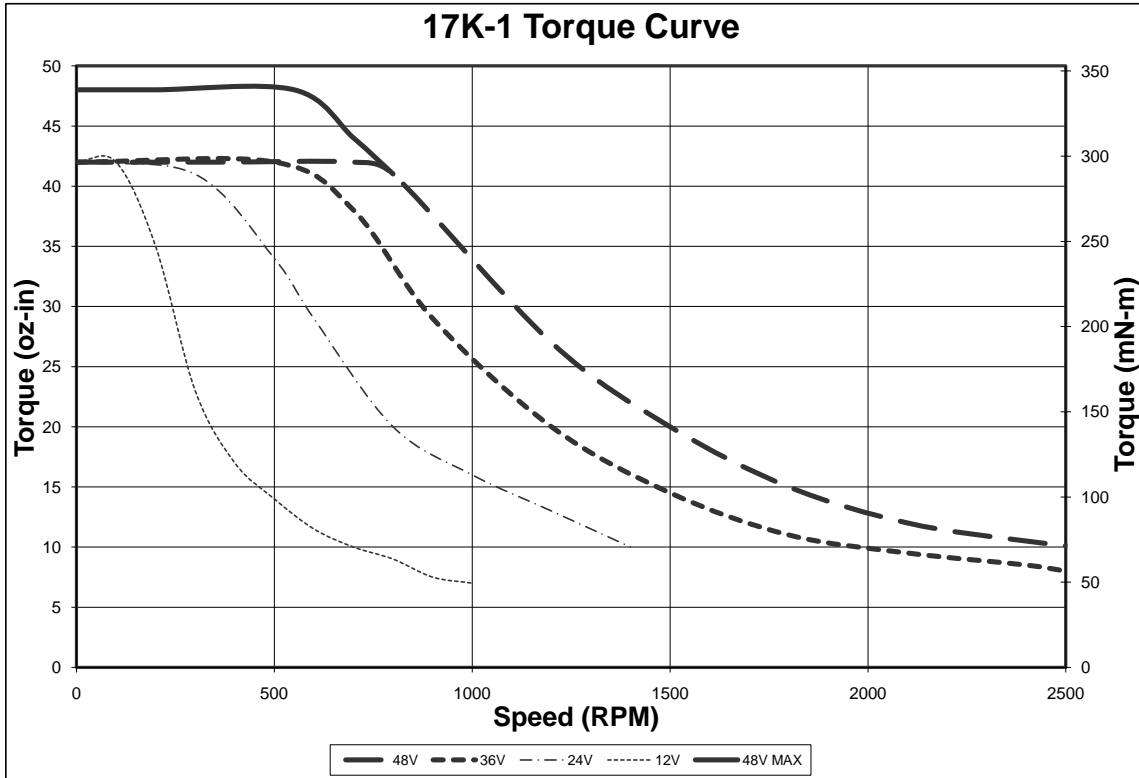

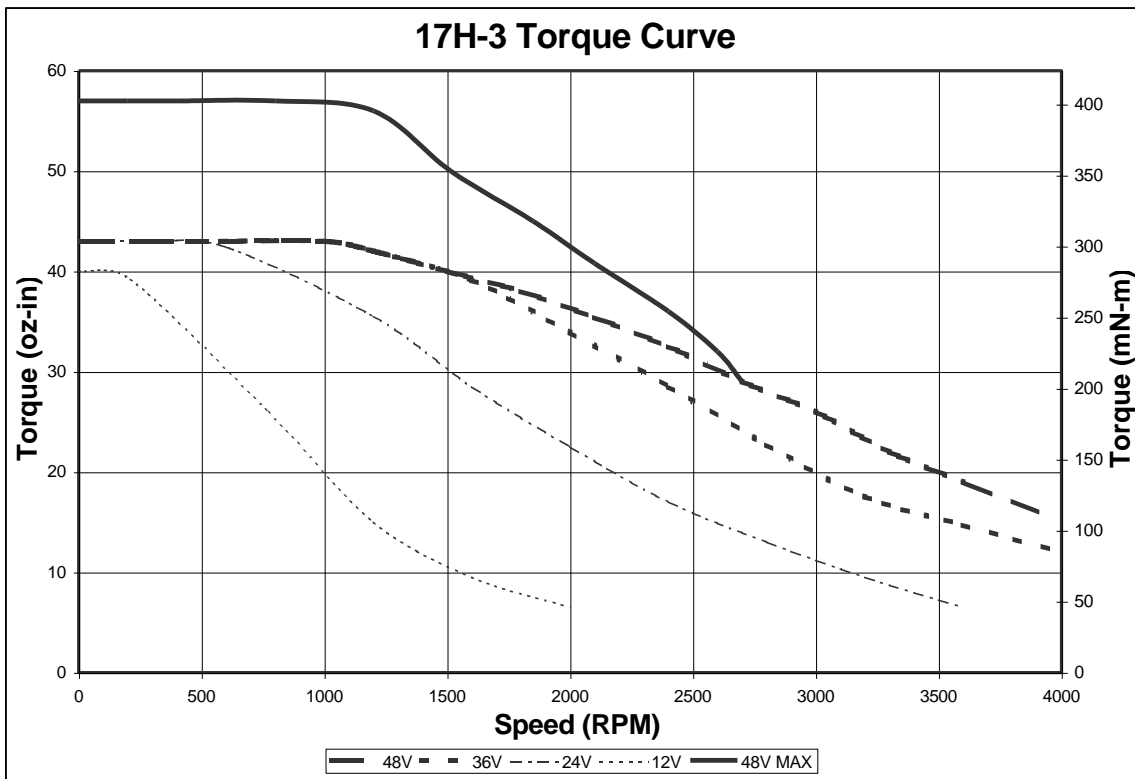
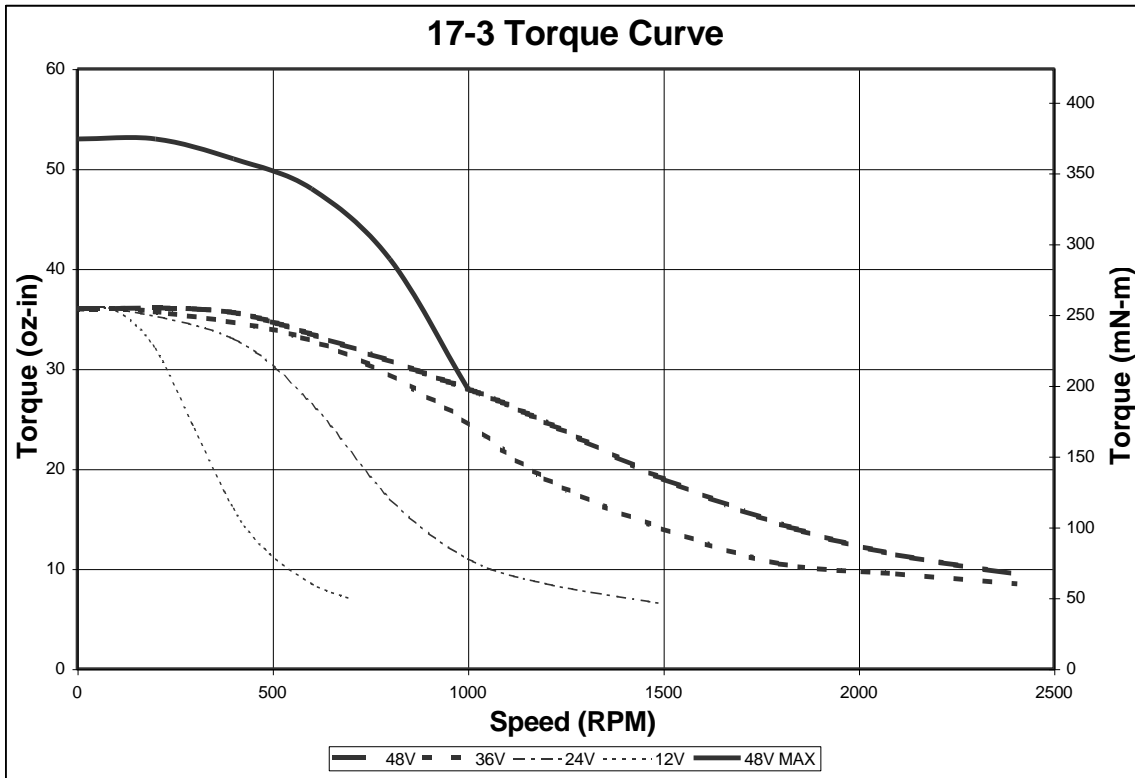

## Electrical Specifications

### Encoder Interface

Encoder Counts Per Revolution: 8000

Index Pulse: 49 - SilverLode controller/drivers internally translate to a single index pulse.

### Motor Memory

I-Grade motors come from the factory with a memory chip containing encoder and motor information. This information is automatically uploaded by the SilverDust IG/IGB controller/driver to simplify the initialization process.

### Temperature Sensor (-6T Option Only)

All QCI IP65 motors contain a sensor to read motor temperature. This sensor automatically reads in the background when controlled by a SilverDust I-Grade controller/driver.

Temperature can be read from a dedicated register and/or used to halt the servo in the case of an over temperature condition.

### Index Alignment

The Index alignment is marked on the shaft and mounting face with a black line. Aligning the line on the shaft with the line on the mounting face will position the shaft approximately at the once per revolution index position for mechanical assembly.

Connector Data

**Standard**

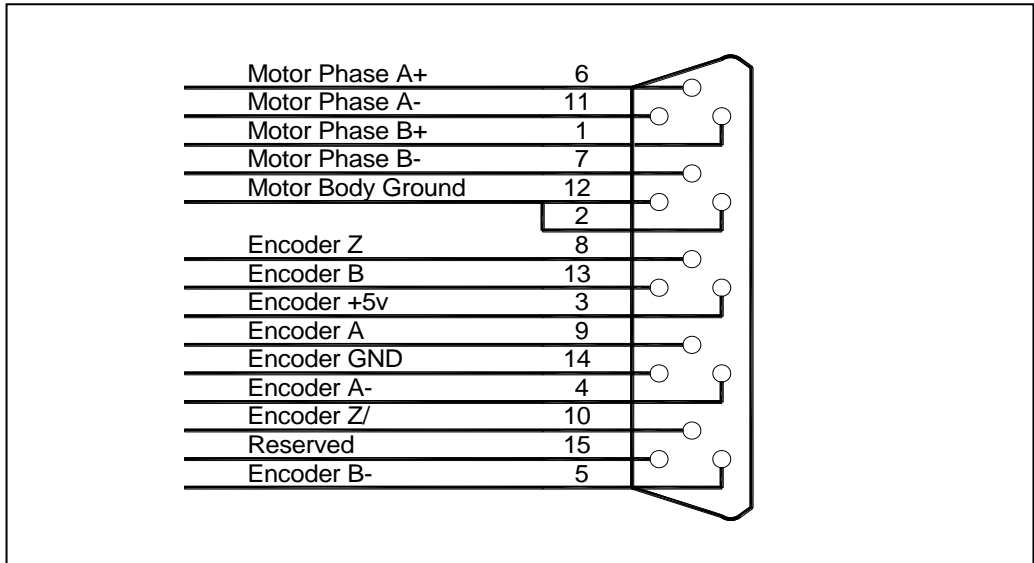

**-6T Option**

Pin	Signals
A	Motor A -
C	+5V
E	Memory
G	Motor B+
J	Motor B -
L	Motor A+
M	Z+
N	Z -
O	A+
P	B -
R	B+
S	GND
T	A-
U	Motor GND

EXPOSED FRONT VIEW OF MOTOR CONNECTOR

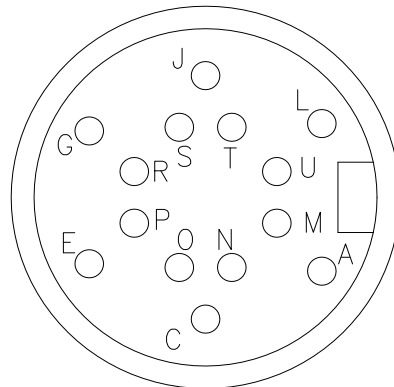



# Mechanical Specifications

## Standard

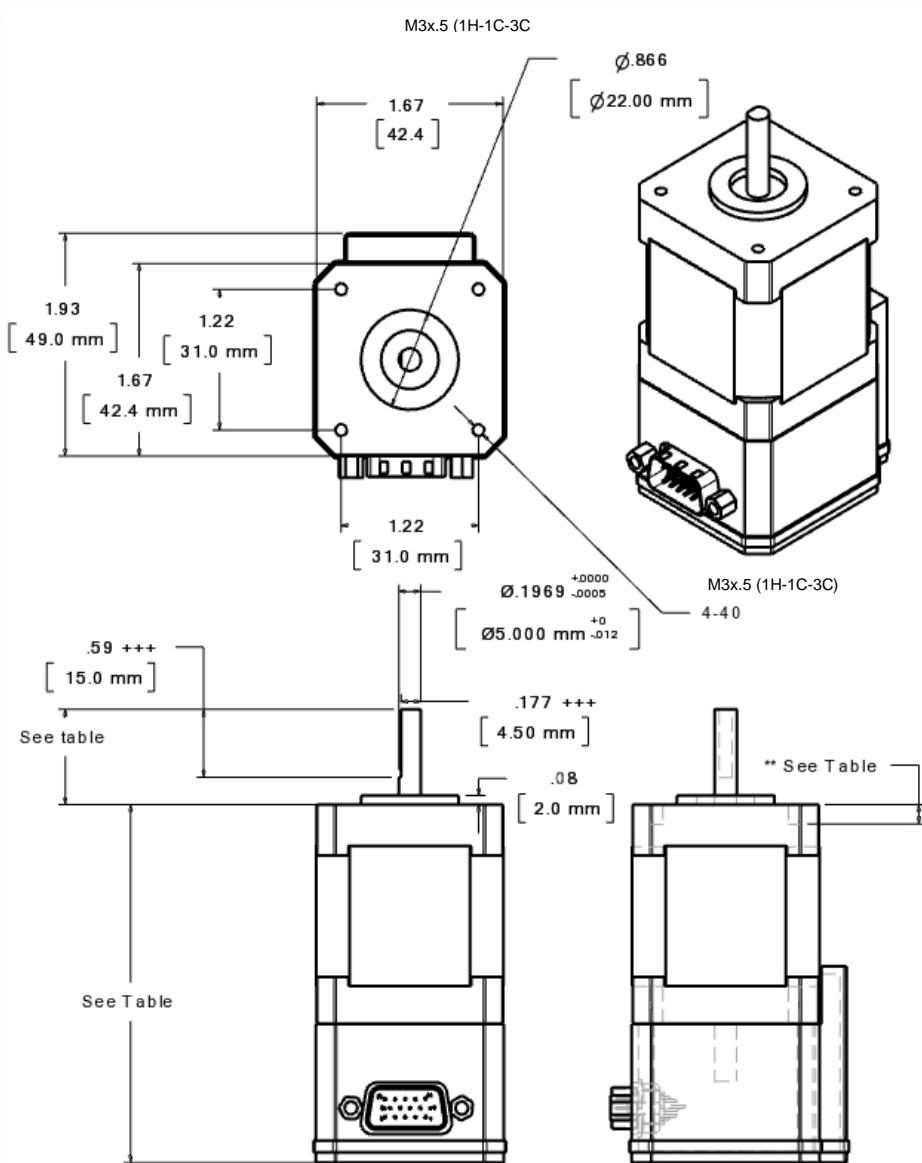

**\*\* QCI-A17H-3C**  
 Minimum hole  
 depth 2.75 mm  
 prior to Serial  
 number A13385

Part Number	Length	Min Hole Depth	Shaft length	Flat +++
QCI-A17-1C	2.6 [66 mm]	0.169 [4.3mm]	0.79 +/- .04 [20+/-1]	
QCI-A17H-3C	3.1 [78 mm]	0.167 [4.25mm] **	0.79 +/- .04 [20+/-1]	Yes
QCI-A17-1	2.6 [66 mm]	0.169 [4.3mm]	0.79 +/- .04 [20+/-1]	Yes
QCI-A17H-1	2.6 [66 mm]			
QCI-A17K-1	2.6 [66 mm]			
QCI-A17-3	3.1 [78 mm]			
QCI-A17H-3	3.1 [78 mm]			

Note: See our website for 2D drawings and 3D models.

**-6T Option**

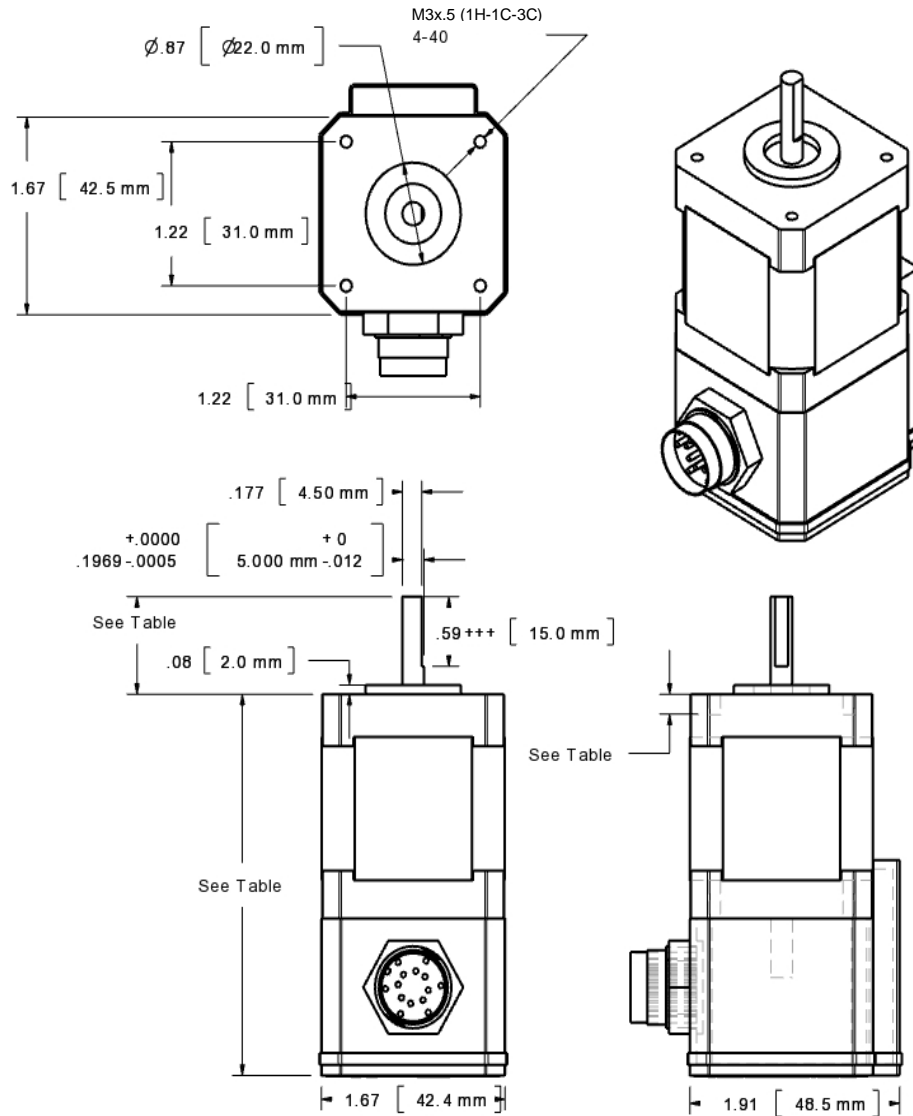

**\*\* QCI-A17H-3C-6T  
Minimum hole  
depth 2.75 mm prior  
to Serial number  
A13385**

Part Number	Length	Min Hole Depth	Shaft length	Flat
QCI-A17-1C-6T	2.7 [69 mm]	0.169 [4.3mm]	0.79 +/- .04 [20+/-1]	
QCI-A17H-3C-6T	3.2 [81 mm]	0.167 [4.25mm] **	0.79 +/- .04 [20+/-1]	Yes
QCI-A17-1-6T	2.7 [69 mm]	0.169 [4.3mm]	0.79 +/- .04 [20+/-1]	Yes
QCI-A17H-1-6T	2.7 [69 mm]			
QCI-A17K-1-6T	2.7 [69 mm]			
QCI-A17-3-6T	3.2 [81 mm]			
QCI-A17H-3-6T	3.2 [81 mm]			

Note: See our website for 2D drawings and 3D models.

**⚠ Note: The motor construction uses a wave spring to compensate for mechanical tolerances and thermal expansion in the axial shaft direction. It is important to not push the shaft into the motor in operation or when mounting gears or pulleys as this may damage the encoder disk.**

## Environmental Specifications

### Operational Temperature

-10 C to +80 C

### Storage Temperature

- 40 C to +85 C

### Humidity

Continuous specification is 95% RH non-condensing.

### Shock

Limitation is approximately 50g/11ms.

### IP Rating - Standard

IP50

### IP Rating (-6T Option)

IP65 is achieved if both a shaft seal and IP65 Motor Interface Cable (QCI-C-D15P-T14S-nn) are used.

NOTE: The IP65 rating is for applications with occasional wash downs. It is not meant for continuous wet applications or high-pressure wash downs. See IP65 spec for more details (CEI IEC 529).

## Recommended Components

### Start-Up Kit

There are several start-up kits available, each based off a servo controller/driver. With a Start-Up kit, power supply and motor/encoder, you will have everything you need to get started. See the Start-Up Kit technical documents on our website for more details.

If you would rather buy the components individually, QCI recommends the following:

**SilverNugget N2 Controller/Driver (QCI-N2-IX) or SilverDust D2 IG/IGM/IGF/IGK Controller/Drivers (i.e. QCI-D2-IG, QCI-D2-IGM, QCI-D2-QCI-D2-IGF, QCI-D2-IGK)**

**SilverSterling S2 Controller/Drivers (QCI-S2-IG-01 or QCI-S2-IGH)**

The motors will work with any of the following controller/drivers. See the indicated datasheets for details:

- SilverDust D2 IGM (QCI-DS043)
- SilverNugget I-Grade N2-IX (QCI-DS031)
- SilverDust D2 IG (QCI-DS019)
- SilverDust D2 IGF (QCI-DS021)
- SilverSterling S2-IG-01 (QCI-DS026)

### Shaft Seal (QCI-17M-65) (-6T Option Only)

The shaft seal (sold separately) is required for an IP65 rating (-6T option) on the shaft end of the motor. The shaft seal consists of an o-ring seal for the motor's pilot and a quad ring seal for the shaft. The shaft seal needs periodical inspections, lubrication, and replacement if worn out.

### SilverLode Manuals (QCI-SLM) QuickControl Software (QCI-QC)

The SilverLode User Manual, SilverLode Command Reference and QuickControl Software are also available on our website. We recommend first time users reading chapter 1 of the User Manual.

### Motor Interface Cable (QCI-C-D15P-D15S-nn)

This cable goes between the motor the SilverLode™ Controller/Driver (SilverDust D2 or SilverNugget N2). Replace the last two digits "nn" with length of cable in feet (i.e – 10 for 10 feet).

### IP65 Motor Interface Cable (QCI-C-D15P-T14S-nn) (-6T Option Only)

This cable goes between the motor and the SilverLode™ Controller/Drive (SilverDust D2 or SilverNugget N2). Replace the last two digits "nn" with length of cable in feet (i.e. –10 for 10 feet).

### Power Supply (i.e. SP-240-48)

A 12-48V power supply producing the amps specified above (see General Motor Specifications) is required. QuickSilver recommends the following power supply for all 17 frame motors. (SP-240-48 : 48V, 5A, 240W)

## Part Number

NEMA 17 I-Grade Motors/Encoders	
MOTOR TYPE/SIZE	MOTOR INTERFACE
<ul style="list-style-type: none"> <li>• <b>A17-1C</b></li> <li>• <b>A17H-3C</b></li> </ul>	<p><b>Blank</b> – Standard</p> <ul style="list-style-type: none"> <li>• DB15HD Motor Interface Connector</li> </ul> <p><b>6T</b> – IP65</p> <ul style="list-style-type: none"> <li>• 14 Pin Round Connector</li> <li>• Shaft seal required for full IP65 rating.                             <ul style="list-style-type: none"> <li>○ QCI-17M-65</li> </ul> </li> <li>• Extra coating on motor exterior.</li> </ul>
<p>To create a part number, choose one from each column above.                      For example: Standard 17-1 with IP65 Option</p>	
<b>QCI-A17-1C</b>	<b>6T</b>
<p>This selection creates the part number: <b>QCI-A17-1-6T</b></p>	

### Standard Stocked Items

QCI-17-1C
QCI-17H-3C

### Special Orders – Contact Factory

All 6T Options
----------------

## Contact Information

QuickSilver Controls, Inc.  
 990 N Amelia Ave  
 San Dimas, CA 91773  
 909-599-6291 or (888) 660-3801  
 909-599-6289 FAX  
[www.QuickSilverControls.com](http://www.QuickSilverControls.com)