

High Current Clamp Modules

This document is for the following High Current (20 Amp) Clamp Modules:

- Clamp Module, High Current, Open Frame (QCI-CLOF-04)
- Clamp Module, High Current, Closed Frame (QCI-CLCF-04)
- Clamp Module, High Current, Closed Frame with a 50-Watt Internal Clamp Resistor
 - 2 Ohm Clamp Resistor (QCI-CLCF-04-R2)
 - 4 Ohm Clamp Resistor (QCI-CLCF-04-R4)

Closed Frame: QCI-CLCF-04
 QCI-CLCF-04-R2
 QCI-CLCF-04-R4

Open Frame: QCI-CLOF-04

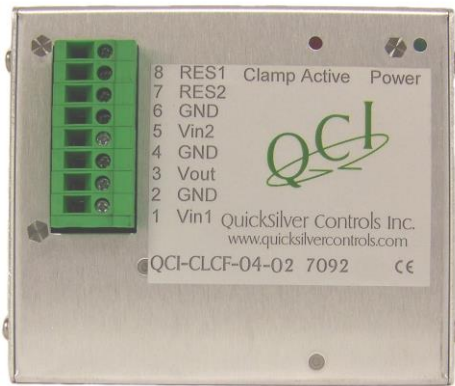

Product Description

The High Current Clamp Module is an active voltage clamping circuit that decouples the DC power supply from the excess power generated by the servos (regeneration) during the deceleration of large inertial loads. Switched mode power supplies respond very poorly to back driving (voltage), which causes their over-voltage shutdown circuitry to trip.

The Clamp Module has an internal diode that isolates the controller/driver(s) from the power supply. If the controller/driver side of the Clamp Module exceeds the power supply voltage by approximately 1.5 Volts, the clamping power MOSFET is switched on, routing the excess voltage into one or more clamp resistors. This voltage routing continues until the output voltage reduces to 0.5 Volts over the input supply voltage. The power MOSFET is then switched off. The Clamp Modules can be used with any input voltage range from +12 to +48 Volts. It is strongly recommended to use only Regulated Power Supplies.

The closed frame versions include a metal box around the Clamp's electronic circuit board. The open frame version has no external metal box but does take up a smaller profile. All modules are DIN mountable.

There is no internal Clamp resistor on the closed frame model QCI-CLCF-04. Resistors must be added to provide voltage clamping (see below). The Clamp resistors QCI uses have a short overload rating of 1.25kwatt-sec and provide nominal protection for most applications. Rapid acceleration/deceleration within the overload rating is acceptable if sufficient time is allowed between each cycle. For example, if the resistor dissipates 1.25kwatt in a sec, allow nine seconds before the next cycle begins. To avoid damaging the resistor and clamping circuit, keep the Clamp Module temperature below 85C for continuous operations. The QCI-CLCF-04-R4 and QCI-CLCF-04-R2 will dissipate 20 watts continuous at 25C ambient. The Clamp Module will be stabilized at approximately 78C in one hour.

Both QCI-CLCF-04-R2 and QCI-CLCF-04-R4 will dissipate the same amount of power but the QCI-CLCF-04-R2 handles slightly more current for the same power ($P=I^2R$).

If the application requires more than 20 watts continuous dissipation, use the QCI-CLCF-04 with external resistors. See clamp resistors below for details.

Why Should the Clamp Module Be Used?

When a servomotor is decelerating a load, the motor is acting as a generator, converting kinetic energy into electrical energy. This power is returned to the power supply. If the power supply cannot “absorb” the extra power, the total DC line voltage becomes greater than what was originating from the DC power supply. Most DC power supplies allow the voltage to rise unabated. In some cases, this can cause failure of the controllers, drivers, motors, and power supplies.

Specific Conditions

- High inertial loads (e.g. Flywheels, Vertical loads, Very efficient slider assemblies).
- Rapid deceleration of any load.
- Multiple servos operating from the same supply.
- Using power supplies with low capacitance regulation circuits.
- Operation of the motor as a brake/clutch to resisting an external mechanical drive.
- Use of 34 frame or larger motors.

What Happens if the Clamp Module is Required but Not Used?

Typically, the controller will “Shut Down” when an over-voltage occurs. This may cause an abrupt halt of the move and may end the currently executing program (depending on the “Kill Motor Condition/Recovery” settings). In many cases, this over-voltage will damage the controller/driver and even the power supply.

Hardware

Input Connections

- Note: Rated @ 20 Amps Continuous
 Note: UL/CSA rating per pin is 20A, VDE rating is 24A)
 Power supply input is connected to Pins 1 & 2.
- Pin 1 = Vin1 = + Volts DC input
 - Pin 2 = Input ground

Output Connections

- Note: Rated @ 20 Amps Continuous
 Clamp module output voltage is on Pins 3 & 4.
- Pin 3 = Vout = + Volts DC output to servo
 - Pin 4 = Output ground to servo(s)

Secondary Input

- NOTE: Rated @ 20 Amps Continuous
 A second input power supply connection is provided on Pins 5 & 6.
- Pin 5 = Vin2 = + Volts DC secondary input
 - Pin 6 = secondary input ground

Connector Description

All High Current Clamp Modules have heavy-duty screw terminal connectors allowing for operating currents up to 20 Amps.

Screw Terminal Connector

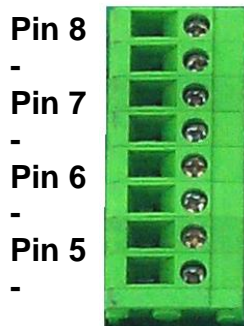

Clamp Module Label (CLCF-04)	Pin	Connection Description
Res1	8	Resistor/Output Voltage
Res2	7	Resistor
Gnd	6	Ground Input 1
Vin1	5	Voltage Input 1
Gnd	4	Output Ground
Vout	3	Output Voltage
Gnd	2	Ground Input 2
Vin2	1	Voltage Input 2

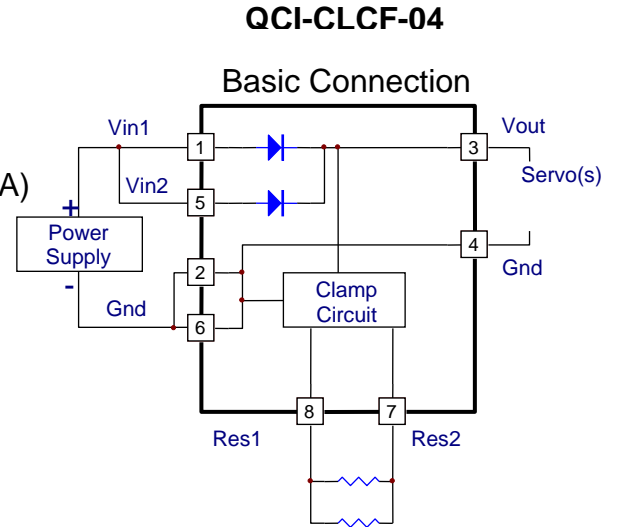

Clamp Resistor(s)

For the QCI-CLOF-04, Clamp resistor(s) must be connected between Pins 7 & 8 on the Clamp Modules. Total resistance should be calculated as follows:

$$R_T = V/I$$

Where V is the supply voltage, and I is the max regenerative current required. For this equation, current (I) can go as high as 24A. For a 48 VDC supply, this corresponds to 2 Ohms of clamping resistance. Remember resistors in series add and resistors in parallel follow the equation:

$$R_T = R_1 * R_2 / (R_1 + R_2)$$

QCI sells 4 Ohm and 8 Ohm clamp resistors, RH-504 and RH-508 respectively.

Design Considerations

- More than one controller/driver may be connected to a Clamp Module as long as the regeneration current of all the units does not exceed that of the Clamp Module.
- Locate the Clamp Module as close to the controller/driver as possible to reduce voltage drop in the line.
- Open switches (i.e. ESTOP) between the controller/driver and the Clamp Module defeat the Clamp Module. If a switch needs to be installed between the Clamp Module and the controller/driver, install a diode biased to allow the servo to dump current to the Clamp.