

## NEMA 17 Mosolver - Motor with integrated feedback

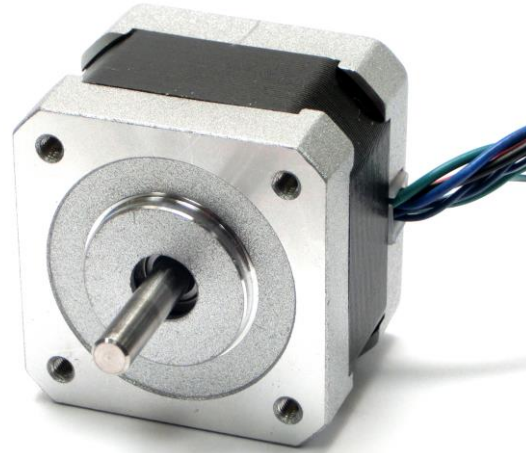
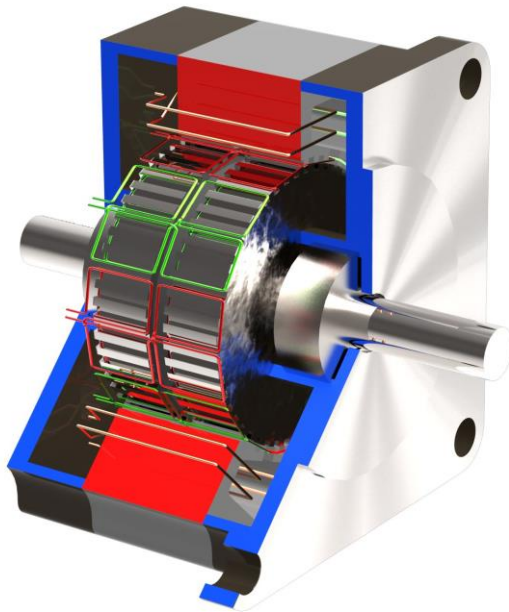

Internal sense coils are added inside the motor (shown symbolically in cut-away) to sense position by intercepting a portion of the flux used to operate the motor. See [www.Mosolver.com](http://www.Mosolver.com) for more details.

Note: Motor specifications (including torque curves) are only true when the motors are used in conjunction with QuickSilver’s SilverSterling™. See the controller datasheets for more details.

### General Motor Specifications

Specifications	MV17C-1	MV17L-1
Maximum Speed (RPM)	2300	2300
48v Optimal Speed (RPM)	1700	1700
Torque (oz-in / Nm) at Optimal Speed	18.5 0.135	18.5 0.135
Continuous Stall Torque oz-in / Nm	30 0.22	28 0.20
Peak Power (Mech. Watts)	29	27

Rotor Inertia oz-in <sup>2</sup> / Kg-m <sup>2</sup>	.18 3.29e-6	.18 3.29e-6
Weight lb / Kg	.61 0.27	.61 0.27
Maximum Driver Input Current (Amps - DC)	0.95 @ 48V 1.3A @24v	1.1A @ 48V 1.5A @24v
Shaft Diameter in / mm	.1968 / 5.00	.1968 / 5.00
Maximum Axial Force lbs /N	2.3 10	6 26
Maximum Radial Force(lbs) @ .62" (15mm) from face	5.8 26	6 26

Greyed entries are EOL; information provided for support purposes.

## Torque Curves

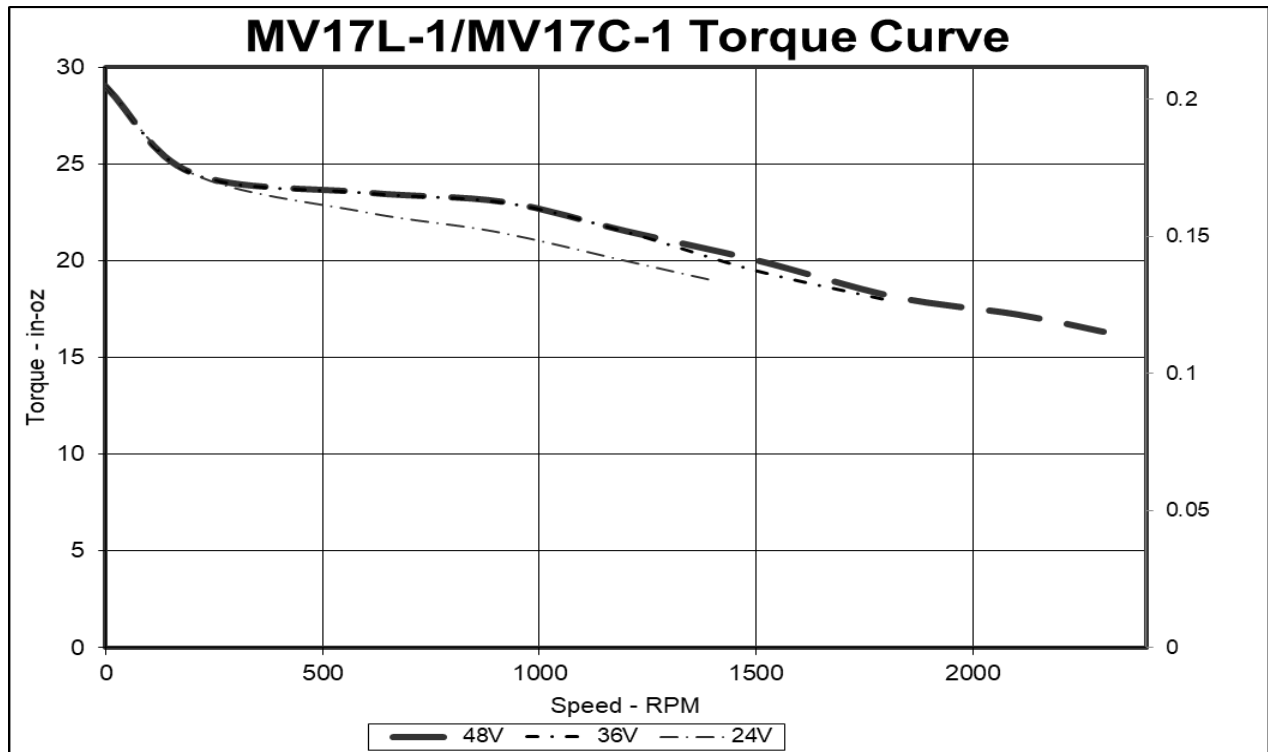

Torque curves represent motor torque at the specified voltage when the TQL command is set to “100%”. These curves represent torque up to 100% duty cycle depending on ambient temperature, heat sinking and air flow.

“Optimal Speed” point provides the maximum available power at “100%” torque setting, which is usually the maximum efficiency point as well. If these two points differ, the “Optimal speed” is approximately the average of the two speeds.

Max speed 2300RPM @ 48v, 1800RPM @ 36v, 1400RPM @ 24v. Operation not suggested below 24v.

## Electrical Specifications

### Feedback Interface

The Mosolver utilizes an internal sense coil which determines position by measuring a portion of the flux from the chopper drive used to drive the motor. The position sensing is only active when the chopper drive is active. The sense amplifiers are within the QCI-S2-IG \*\*

### Motor Memory

These motors come from the factory with a memory chip containing feedback configuration and motor information. This information is automatically uploaded by the SilverSterling™ S2's controller/drivers to simplify the initialization process.

### Wiring

Motor includes 12" cable (including connector) which may connect directly to the QCI-S2-IG motor/encoder connector, or may be used with up to a 10' QCI-C-D15P-D15S-xx motor/encoder cable.

\*\* Available after S/N 2S2000

## Connector Data

Standard DB-HD15 pin

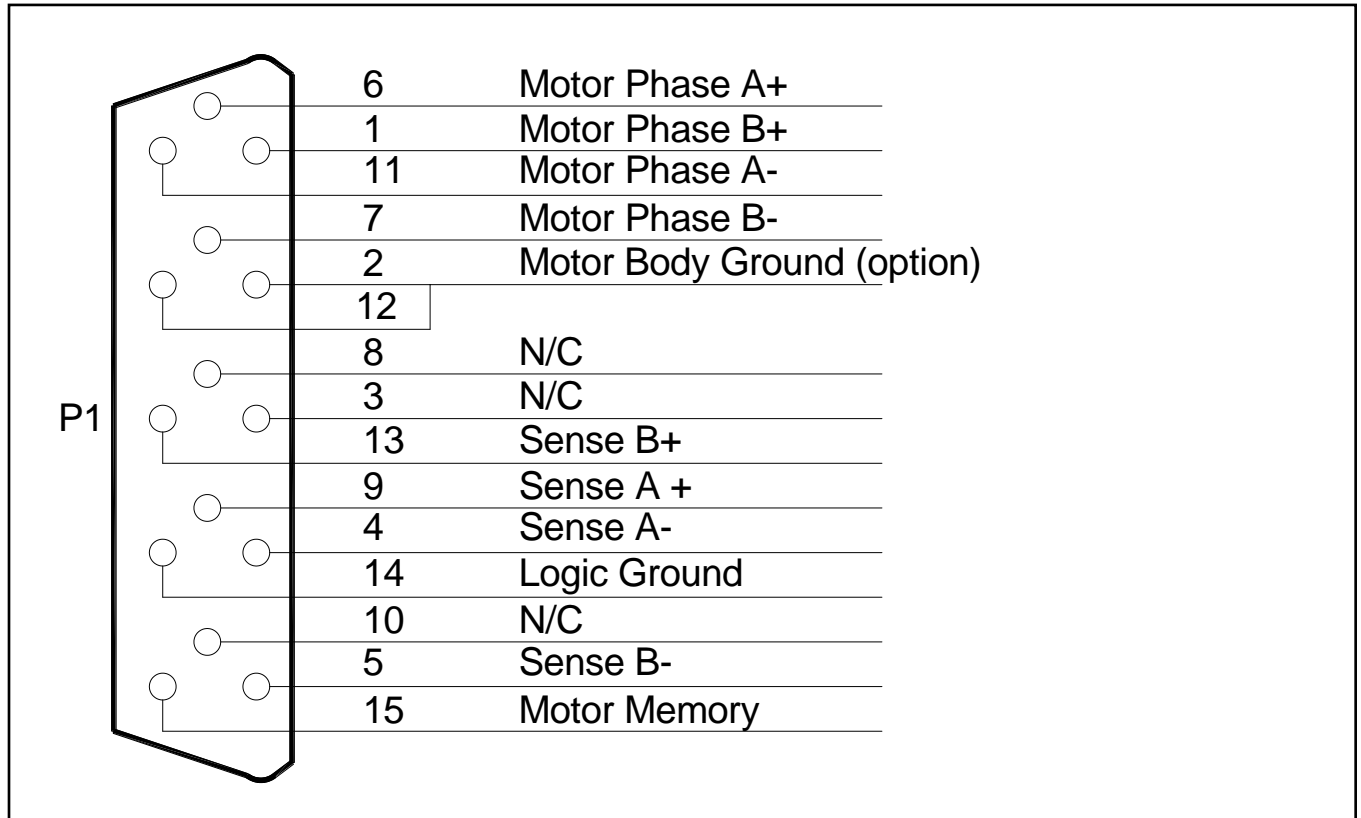

**⚠ Note:** The motor construction uses a wave spring to compensate for mechanical tolerances and thermal expansion in the axial shaft direction. Pushing in / pulling out the shaft while operating may affect sensor accuracy. High forces on the shaft will shorten bearing life and excessive levels may cause immediate failure of the shaft and/or bearings. Do NOT strike with a hammer or impact tool! Support rear shaft if pressing a gear or pulley.

### Mechanical Specifications

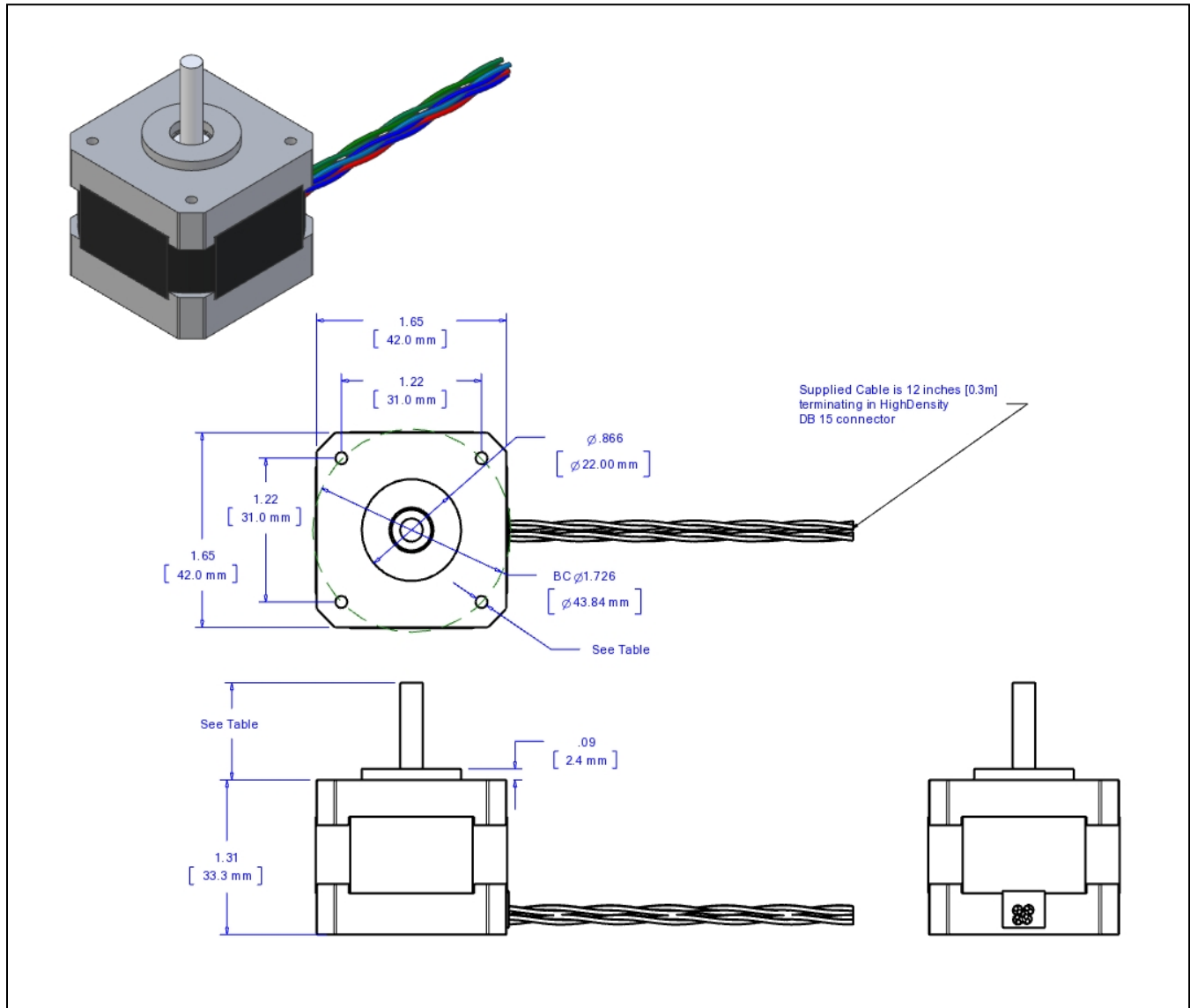

Motor Series	Shaft Length	Shaft diameter	Mounting Hole
MV17C-1	0.77 [19.4 mm]	0.197 [5.00 mm]	M3X.05 ↓0.17 [4.5mm] min
MV17L-1	0.95 [24.1 mm]	0.197 [5.00 mm]	4-40

## Environmental Specifications

### Operational Temperature

-10 C to +80 C

### Storage Temperature

-40 C to +85 C

### Humidity

Continuous specification is 95% RH non-condensing.

### Shock

Limitation is approximately 50g/11ms.

### IP Rating - Standard

IP50

## Part Numbers

NEMA17 Mosolver	
MOTOR TYPE/SIZE	MOTOR INTERFACE
<ul style="list-style-type: none"> <li>QCI-MV17C-1</li> </ul>	<b>Blank</b> – Standard <ul style="list-style-type: none"> <li>DB15HD Motor Interface Connector</li> </ul>
<ul style="list-style-type: none"> <li>QCI-MV17L-1</li> </ul>	<b>Blank</b> – Standard <ul style="list-style-type: none"> <li>DB15HD Motor Interface Connector</li> </ul>
To create a part number, choose one from each column above. For example: QCI-MV17C-1	
<b>QCI-MV17C-1</b>	
This selection creates the part number: <b>QCI-M17C-1</b>	

## Contact Information

QuickSilver Controls, Inc.  
 990 N Amelia Ave  
 San Dimas, CA 91773  
 909-599-6291 or (888) 660-3801  
 909-599-6289 FAX  
[www.QuickSilverControls.com](http://www.QuickSilverControls.com)  
<http://www.quicksilvercontrols.com/>