

SilverSterling Basic Breakout – QCI-BO-S1

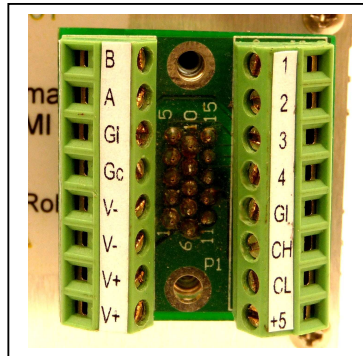

QCI-BO-S1

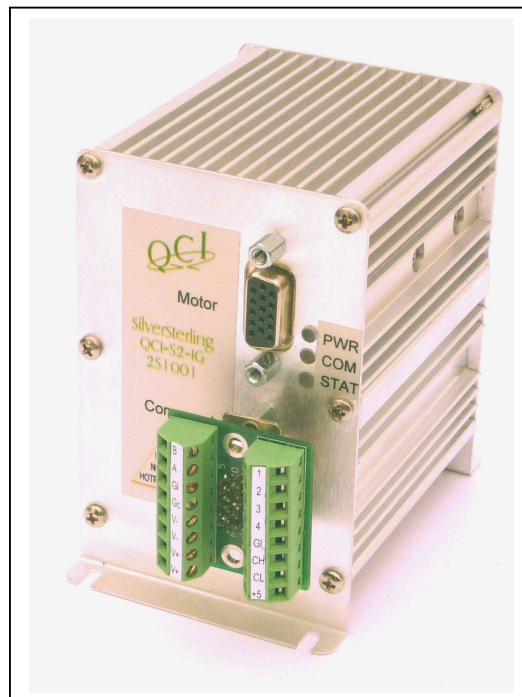

QCI-S2-IG with QCI-BO-S1

Product Overview

The Basic Breakouts connect directly to the SilverSterling's 15-pin interface port (SIP), which breakout power, RS-485 communication, CAN and 4 I/O.

The provided screws lock the breakouts to the DB15HD connector. There are two, 8 position terminal blocks that breakout all 15 pins.

Terminal Connector Wire Range: 16-28 AWG

Pin-out Descriptions

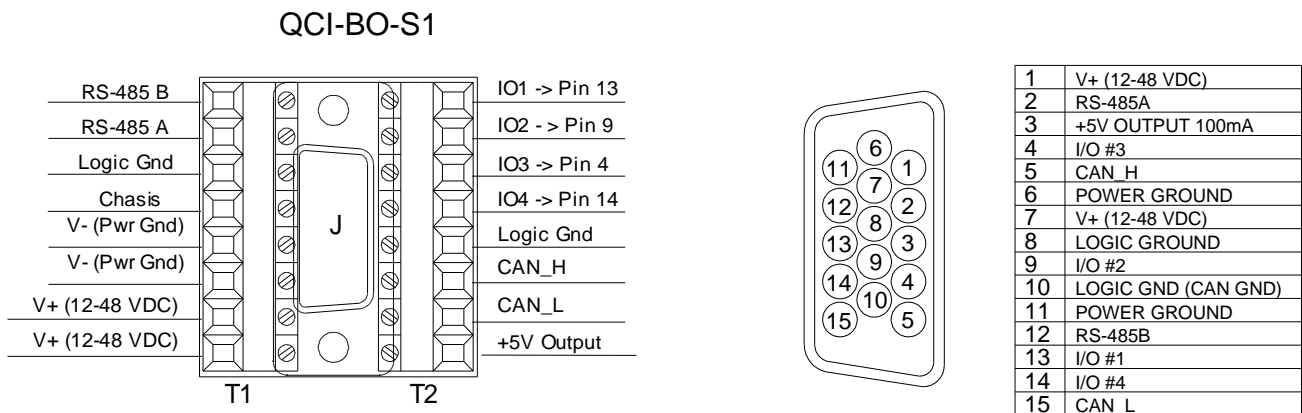

How to Use

Single axis configuration:

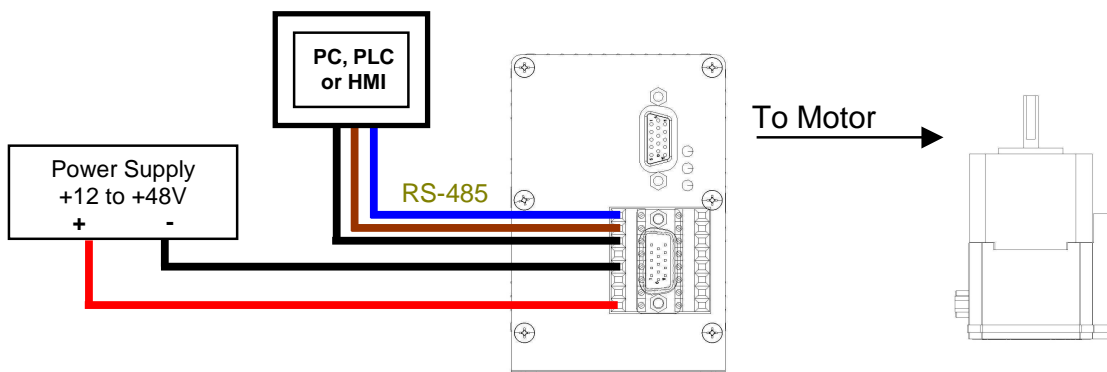

Note: It is **NOT** recommended to daisy chain power supply for more than 2 units due to current limitation on the breakout board.